

High-Pressure Pumps for technical water, type PAH



Introduction

The Danfoss High-pressure water pumps are especially designed for operation on technical water, such as reverse osmosis-, demineralised- and de-ionised water.

Twelve pump sizes with displacements from 2 to 80 ccm/rev in 4 different frame sizes are available providing flow in the range from 50-8000 l/h or 0.25-35 gpm.

The axial piston principle provides very high efficiency, small and compact design and long service life.

The Danfoss pumps are water lubricated and do not involve any other lubricant, making this unique pump maintenance free over its entire service life.

Features

- Maintenance free, due to water lubrication and direct drive (no belt)
- Very high efficiency compared to centrifugal and triplex plunger pumps
- Small, compact and light design
- Negligible pressure pulsation, no need for pulsation dampeners
- Extreme recirculation capability without overheating (up to 90%)
- Wide speed control range
- All stainless steel design
Fulfils most stringent hygiene requirements, i.e. VDI 6022, HACCP
- Available as ATEX certified

Technical data

Pump size	2	3.2	4	6.3	10	12.5	25	32	50	63	70	80
Geometric displacement cm ³ /rev	2	3.2	4	6.3	10	12.5	25	32	50	63	70	80
Max. continuous discharge pressure, bar/psi	100/1450	100/1450	100/1450	100/1450	140/2000	140/2000	140/2000	140/2000	80/1150	140/2000	140/2000	140/2000
Min. speed, rpm	1000	1000	1000	1000	1000	1000	1000	1000	1000	1000	1000	1000
Max. speed, rpm	3000	3000	3000	3000	2400	2400	2400	2400	1800	1800	1800	1800
Typical flow at: 1500 rpm in l/h 1800 rpm in gpm	100 0.5	200 1.0	300 1.5	500 2.5	750 4	1000 5	2000 10	2500 12.5	4000 20	5000 25	5500 30	6250 35
Typical motor size:												
at max. pressure in kW, (1500 rpm)	0.75	1.1	1.5	2.2	4	5.5	11	15	11	30	30	30
at max. pressure in HP, (1800 rpm)	1	1.5	2	3	7.5	10	20	25	15	40	50	50
Weight, kg/lbs	4.4/9.7	4.4/9.7	4.4/9.7	4.4/9.7	7.7/17.0	7.7/17.0	16.0/35.3	16.0/35.3	31.0/68.3	31.0/68.3	31.0/68.3	31.0/68.3

Application examples

- Open space direct humidification
- Humidifiers in HVAC (duct humidification)
- Adiabatic cooling systems
- Dust suppression and odour control systems
- Turbine industry:
 - Inlet fogging
 - NOx-control
 - High-pressure cleaning
- NOx-control in Diesel engines
- Chemical and pharmaceutical industry
- Aseptic high-pressure cleaning
- Special effects

Flow

- Theoretical flow: $Q_{(th)}$ [l/min] = pump displacement in cm³ × rpm/1000
- Flow at max. pressure: The flow at max. pressure $Q_{(p_{max})}$ is shown in the table below
- Flow at any pressure: At zero pressure the true flow equals the theoretical flow $Q_{(th)}$.
- The flow (Q_{eff}) at less than max. pressure (p_{max}) can be calculated with the following equation: $Q_{eff} = Q_{(th)} - [(Q_{(th)} - Q_{(p_{max})}) \times (p / p_{max})]$

Motor dimensioning

Required motor power:
From the following table you can determine the rpm's of the pump at the desired flow.
Calculate as follows:

$$P \text{ [in kW]} = \frac{\text{Speed [in rpm]} \times \text{displacement per rev [in ccm]} \times \text{pressure [in bar]}}{600.000 \times \eta_{\text{mech}} \text{ (mechanical efficiency)}}$$

The required torque is calculated as follows:

$$M \text{ [in Nm]} = \frac{\text{Displacement [in ccm]} \times \text{pressure [in bar]}}{62.8 \times \eta_{\text{mech}} \text{ (mechanical efficiency)}}$$

To determine the correct motor size, both the power and torque requirement must be verified.

The mechanical efficiency of the pump is estimated as follows:

PAH 2, 3.2, 4, 6.3	0.8
PAH 10, 12.5	0.85
PAH 25, 32	0.9
PAH 50, 63, 70, 80	0.95

Flow

Typical flow at maximum pressure in Litres per minute:

	PAH2	PAH3.2	PAH4	PAH6.3	PAH10	PAH12.5	PAH25	PAH32	PAH 50	PAH63	PAH70	PAH80
RPM	Flow	Flow	Flow	Flow	Flow	Flow	Flow	Flow	Flow	Flow	Flow	Flow
1000	0,9	2,3	3,1	5,5	8,0	10,5	21,7	29,1	44,8	53,2	61,3	71,4
1100	1,1	2,6	3,5	6,1	9,0	11,7	24,2	32,2	49,7	59,4	68,2	79,3
1200	1,3	2,9	3,9	6,7	9,9	13,0	26,6	35,3	54,7	65,6	75,0	87,2
1300	1,5	3,3	4,3	7,3	10,9	14,2	29,1	38,5	59,6	71,7	81,9	95,0
1400	1,7	3,6	4,7	8,0	11,9	15,4	31,5	41,6	64,6	77,8	88,7	102,9
1500	1,9	3,8	5,1	8,6	12,8	16,5	34,0	45,0	69,5	84,0	95,6	110,7
1600	2,1	4,2	5,5	9,2	13,8	17,8	36,5	47,9	74,4	90,0	102,3	118,7
1700	2,3	4,5	5,9	9,8	14,8	19,0	38,9	51,0	79,4	96,0	109,0	126,2
1800	2,5	4,9	6,3	10,4	15,8	20,2	41,3	54,1	84,4	101,9	115,6	133,8
1900	2,7	5,2	6,7	11,0	16,7	21,5	43,9	57,3				
2000	2,9	5,5	7,1	11,7	17,7	22,7	46,3	60,4				
2100	3,1	5,8	7,5	12,3	18,7	23,9	48,8	63,5				
2200	3,3	6,1	7,9	13,0	19,6	25,1	51,2	66,6				
2300	3,5	6,4	8,3	13,6	20,6	26,3	53,7	69,7				
2400	3,7	6,7	8,7	14,2	21,6	27,6	56,1	72,9				
2500	3,9	7,0	9,1	14,8								
2600	4,1	7,3	9,5	15,4								
2700	4,3	7,6	9,9	16,1								
2800	4,4	8,0	10,3	16,7								
2900	4,6	8,3	10,7	17,3								
3000	4,8	8,6	11,1	17,9								

Operation conditions
Inlet pressure:

PAH 2-12.5 can be directly fed from a tank (flooded suction) or from a pressurized supply. The minimum supply pressure is 0 bar/0 psi. The maximum supply pressure is 4 bar/60 psi.

PAH 25-80 must be fed from a tank (flooded suction).

The maximum supply pressure is 3 m/10 ft water column.

For installations with unstable supply pressure a suitable pressure reduction valve and an electric shut off valve are recommended to protect the pump against damage.

Temperature:
Water temperature:

- Min. +3°C/37.4°F, max. 50°C/122°F at max. discharge pressure
- Max. 60°C/140°F at max. 100 bar/1450 psi discharge pressure (PAH 50-80)

Ambient temperature:

- Min. 0°C/32°F to max. 50°C/122°F

Storage temperature:

- Min. -40°C/-40°F to max. 70°C/158°F (with factory antifreeze preservation)

Noise level

Since the pump typically is mounted on a bell housing or frame, the noise level can only be determined for the complete unit (system). It is therefore very important that the pump is mounted correctly on a frame with dampers to minimize vibrations and noise. Furthermore the pump discharge should be connected with the application i.e. with a flexible high-pressure hose.

The noise level is influenced by:

- The speed of the pump, high rpm create more noise than low rpm
- The discharge pressure, high pressure generates more noise than low pressure
- Rigid mounting of the pump generates more noise than flexible mounting
- Pipe mounting direct to the pump increases the noise level compared to a flexible hose

Technical water

Technical water may be divided into 3 groups:

- Softened water (cation exchanged).
- Demineralized water (Demineralized/de-ionized water)
- Water processed according to the reverse osmosis principle (RO-water)

Descriptions of the specific processes are always enclosed with the systems for making softened, demineralized and reverse osmosis-water.

When using other fluids like HFA, HFC etc., please contact Danfoss Sales Organization.

Softened* and demineralized* water are not to be used for drinking water in most European countries as the chemicals used for the processes are harmful/hazardous to human beings .

*only applying to units being regenerative.

Corosion and antifreeze protection

If the pump is exposed to temperatures below freezing, it must be protected against freezing. See also paragraph on *Operation Conditions*.

Producers of DOWCAL N and CHILLSAFE recommend a mixture ratio of min. 30% DOWCAL N/CHILLSAFE to prevent biofilm occurrence in the system due to DOWCAL N and CHILLSAFE being biologically de-gradable.

Danfoss recommends DOWCAL N or CHILLSAFE antifreezes both being a biologically degradable Mono Propylene Glycol.

(DOWCAL N is produced by POLO).
(CHILLSAFE is produced by ATCO).

Corrosion protection

If the system is decommissioned for more than 4 weeks or in transportation, the pump must be preserved against corrosion. Never just drain the pump!

See instructions delivered with the pump.

Service

The PAH pumps are maintenance free over their entire service life. To achieve the maximum service life, proper water supply and filtration are mandatory.

Variable speed operation:

The PAH pumps can be operated within the above described speed range (see flow table). Variable speed operation is defined as running the pump at various speeds according to a typical duty cycle. In such case the minimum service life expectancy depends on the duty cycle.

The service life expectancy depends on the operation conditions:

Constant speed operation:

When operated with a standard 4-pole AC motor in the speed range of 1400 rpm (50 Hz) and 1800 rpm (60 Hz), the pumps reach their maximum service life.

For continuous operation below 1400 rpm or above 1800 rpm, please contact the Nessie Sales Organisation at Danfoss.

Installation

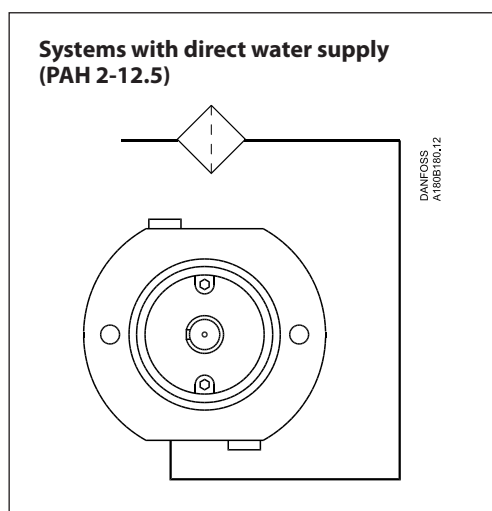

In order to eliminate the risk of cavitation, a positive inlet pressure is always to be maintained.

- 1) Place the filter in the water supply line before the pump.
- 2) Place a monitoring pressure switch set at min. 0,9 bar abs. between filter and pump inlet. The monitoring switch must stop the pump at lower pressure than min. 0.9 bar/13 psi abs.

To ensure best possible bleeding of the pump and to avoid air pockets, the pump should be mounted vertically with the shaft pointing upwards or horizontally with the discharge at the highest point.

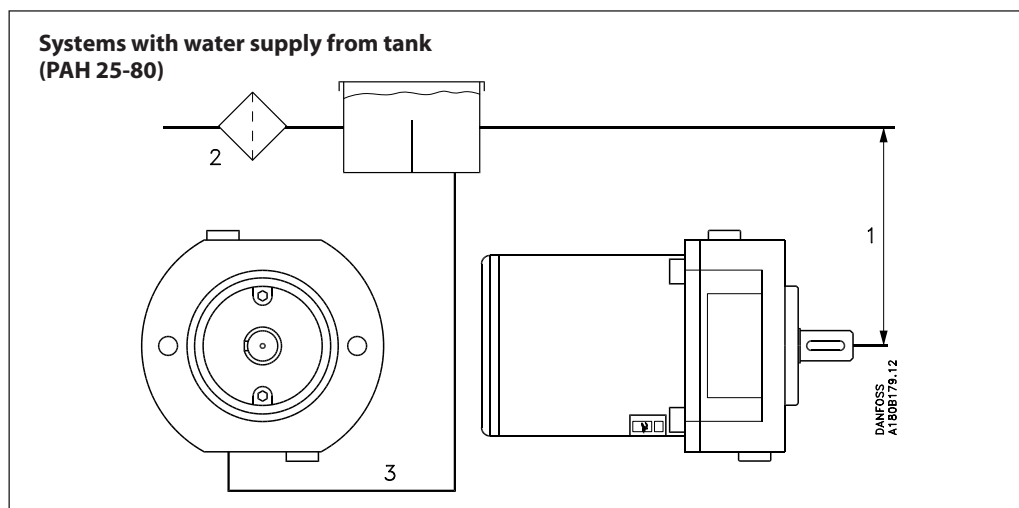

In order to eliminate the risk of cavitation, a positive inlet pressure should always be maintained by observing the following guidelines:

- 1) Place the tank above pump inlet (water level in the tank should always be above the pump).
- 2) Place filter in the water supply line before the tank.

- 3) Dimension the inlet line with minimum pressure drop (large internal diameter, minimum length of pipe, avoid bends, and fittings with small internal diameter.)

Direction of rotation

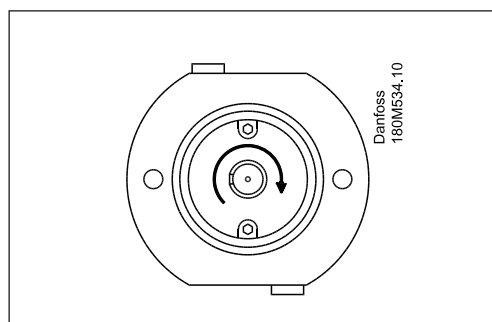

Clockwise (CW) seen from the pump shaft end (illustrated by a PAH 10/12.5).

Motor connection

The pump must not be exposed to axial nor radial loads. We therefore recommend the use of a flexible coupling for connection to an electric motor or a combustion engine.

Below figure illustrates how to mount the pump and connect it to electric motor/combustion engine.

- A: Flexible coupling
- B: Bell housing
- C: Motor shaft

If an alternative mounting is required, please contact Danfoss Sales Organization for further information.

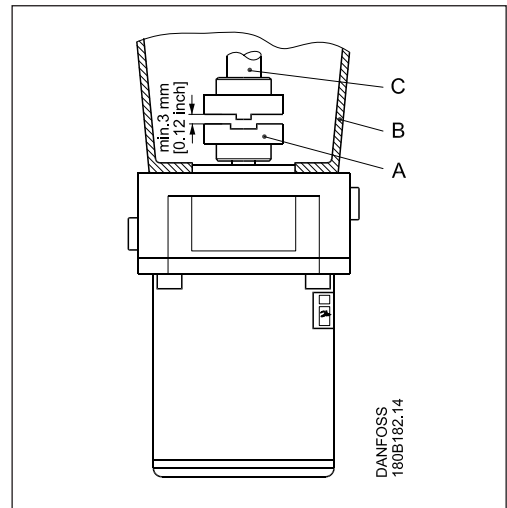

To ensure easy mounting of the flexible coupling without using tools, the tolerances must be dimensioned accordingly.

Make sure to observe the recommended mounting tolerances for the flexible coupling used, as any axial load on the shaft must be avoided.

Danfoss offers bell housing and coupling-kits. Please contact the Danfoss Sales Organization.

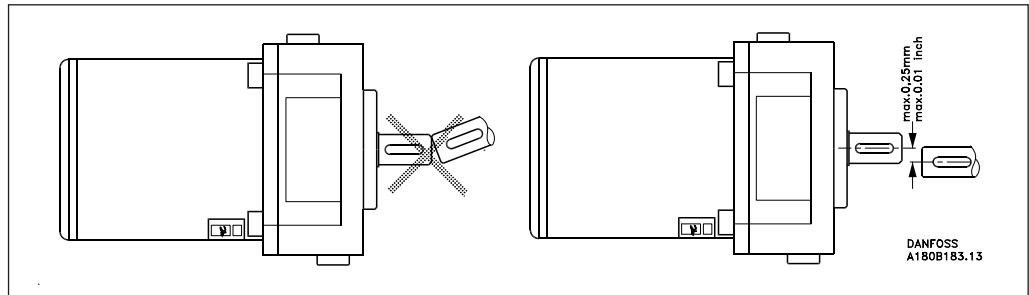

Tank

The function of the water tank is to continuously supply clean water, divert heat, remove air and to allow for variations of the water volume.

Minimum tank capacity is dimensioned according to the volume required for water cooling, and for water expansion.

Normally, a tank capacity of >0,7 times the pump flow (per min.) will be sufficient as long as there is a water renewal of >15% of the pump flow.

Direct the suction line to the pump bottom, approx. 1.5 times the suction line diameter "D" above the bottom to prevent precipitated impurities from being sucked in. Always keep all tank connections (suction, drain and return) below water level in the tank. Drain and return lines to be placed as far from the suction line as possible and preferably separated by a dividing plate in the tank. Additionally the suction, drain, and return lines must be cut at a 45° angle (see example).

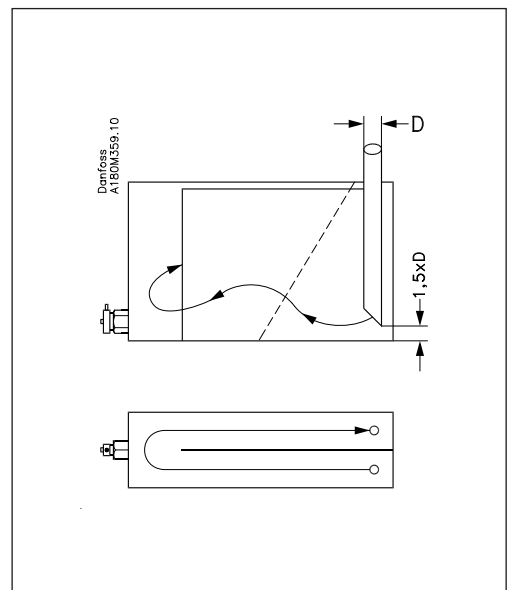

Operation

Start-up:

The system has to be flushed prior to start-up to remove possible impurities from pipes, hoses etc.

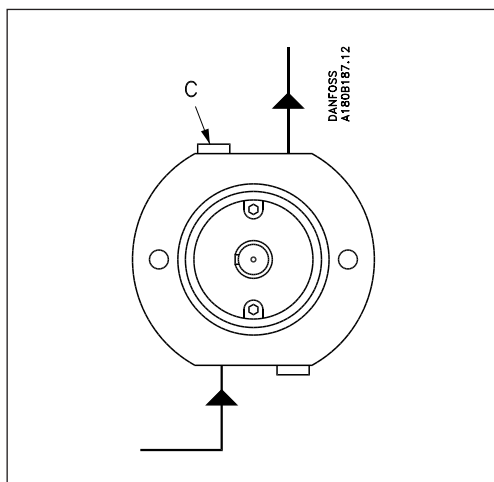

Before starting the pump, the top bleeding plug "C" is loosened. When water appears from the bleeding plug, the pump is filled with water, and the plug is retightened. Make sure that rotation direction of the pump is correct.

With its suction line connected to the water supply or the tank, the pump is now started with open outlet P-port.

At the initial start of the system, the pump should be run without pressure for about 5 minutes to remove possible impurities from pipes, hoses, etc.

Systems must be flushed with water for min. 30 minutes (please see Instructions for "Cleaning of Water Hydraulic Systems"). When the flushing is completed the filter element must be changed.

Safeguarding of Pump during Operation:

When running, the pump must always be connected to the water supply to prevent the pump from running dry.

In systems with water tank it is recommended to build in a level gauge which will make the pump stop at too low water level.

In open-ended systems without a tank it is recommended to install a pressure switch between filter and pump suction connection to ensure that the pump stops at 0 bar/0 psi to prevent the pump from running dry.

For all systems it is recommended to install a temperature gauge for stopping the pump when the water temperature exceeds 50°C/122°F.

Filter:

After start-up it is recommended to change filter element after 1-10 hours' operation.

Subsequently, the filter element is changed when 'clogged filter' is indicated.

Disconnection:

If the inlet line to the pump T-port is disconnected from the water supply, the pump will be emptied of water.

Before starting the pump again, the starting procedure described in the Start-up-paragraph must be followed.

Transport and Storage Precautions

If emptied of water, the system must be protected against corrosion with a glycol mixture (minimum 35% monopropylene glycol).

The protection must be made within 2 days after the emptying.

If there is risk of exposure to temperatures below the freezing point during transport or storage, the system likewise has to be flushed with a glycol mixture (minimum 35% monopropylene glycol).

For further information on anti-freeze media, please contact Danfoss Sales Organization.

Recommended procedure:

1. Disconnect the water supply to the pump/system.
2. Empty the pump through the lower bleeding plug. Retighten the plug when the pump is empty.
3. Connect the pump to a tank with anti-freeze additive. Connect a hose to the pump P-port and the other end of the hose back to tank.
4. Quickly start and stop the pump. Make sure that the pump does not run dry.
5. Empty pump of anti-freeze medium (through the lower bleeding plug). Remount and retighten the bleeding plug, when the pump is empty.
6. The pump is now protected against internal corrosion and frost.

Filtration

The water must be filtered through a 10 µm absolute filter with a β_{10} -value > 5000 (or better).

For further filter details, please contact the Danfoss Sales Organisation.

Code numbers

Pump	
PAH 2	180B0031
PAH 3.2	180B0077
PAH 4	180B0030
PAH 6.3	180B0029
PAH 10	180B0032
PAH 12.5	180B0033
PAH 25	180B0038
PAH 32	180B0039
PAH 50	180B0046
PAH 63	180B0043
PAH 70	180B0044
PAH 80	180B0045

ATEX - For ATEX ordering and related information, consult the document "Pumps intended for use in ATEX classified areas" 521B1102

Dimensions for PAH 2,
PAH 3.2, PAH 4 and PAH 6.3
in mm

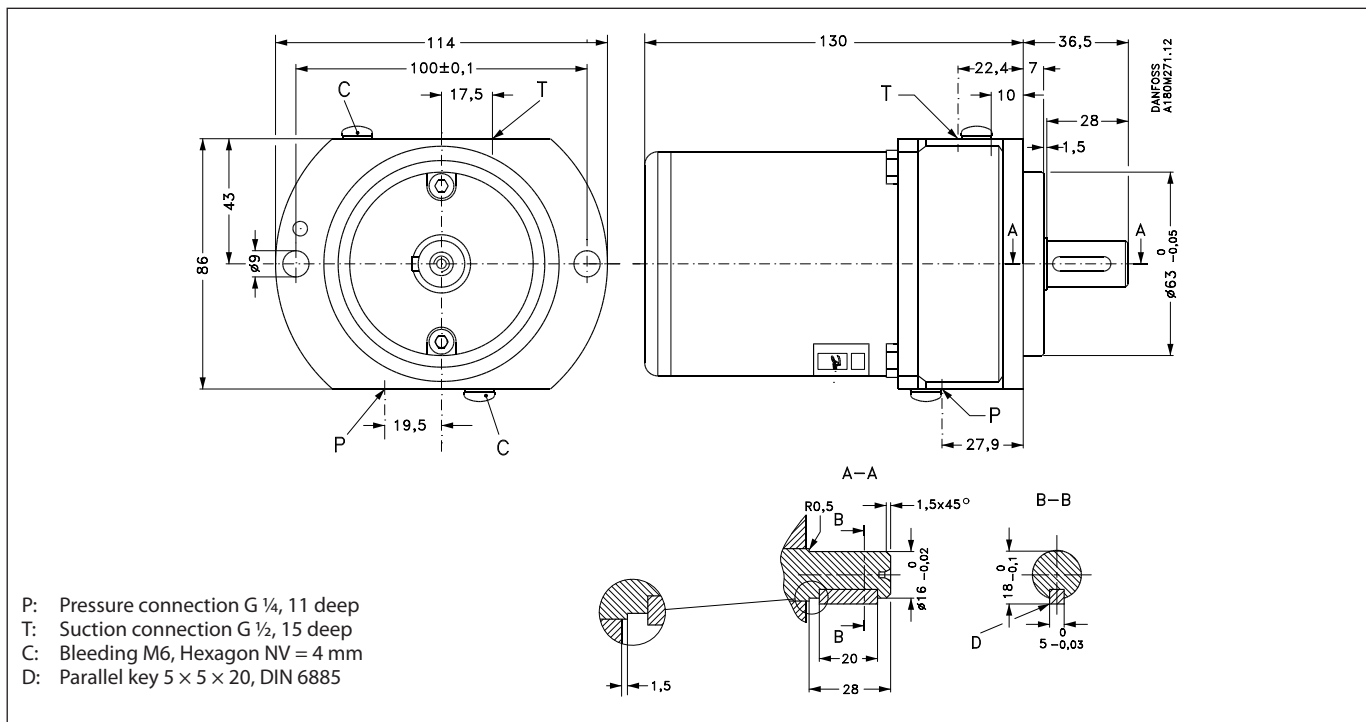

Dimensions for
PAH 25 and PAH 32
in mm

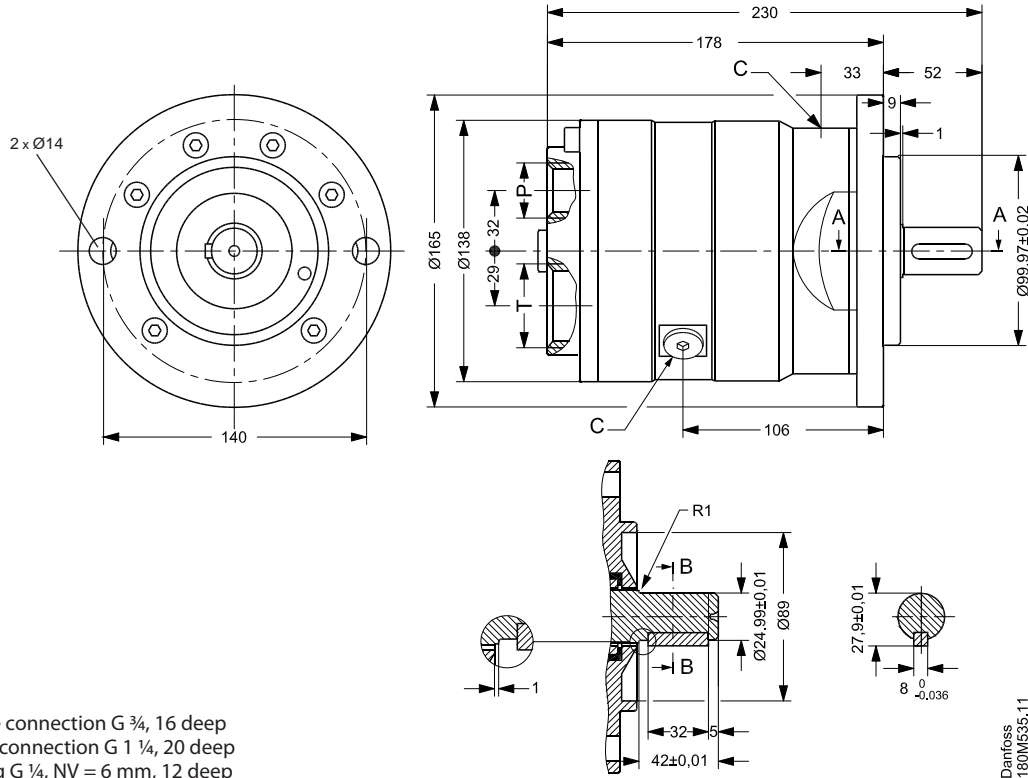

- P: Pressure connection G 3/4, 16 deep
- T: Suction connection G 1 1/4, 20 deep
- C: Bleeding G 1/4, NV = 6 mm, 12 deep
- D: Parallel key 8 x 7 x 32, DIN 6885

Danfoss
180M535.11

Dimensions for PAH 50,
PAH 63, PAH 70 and PAH 80
in mm

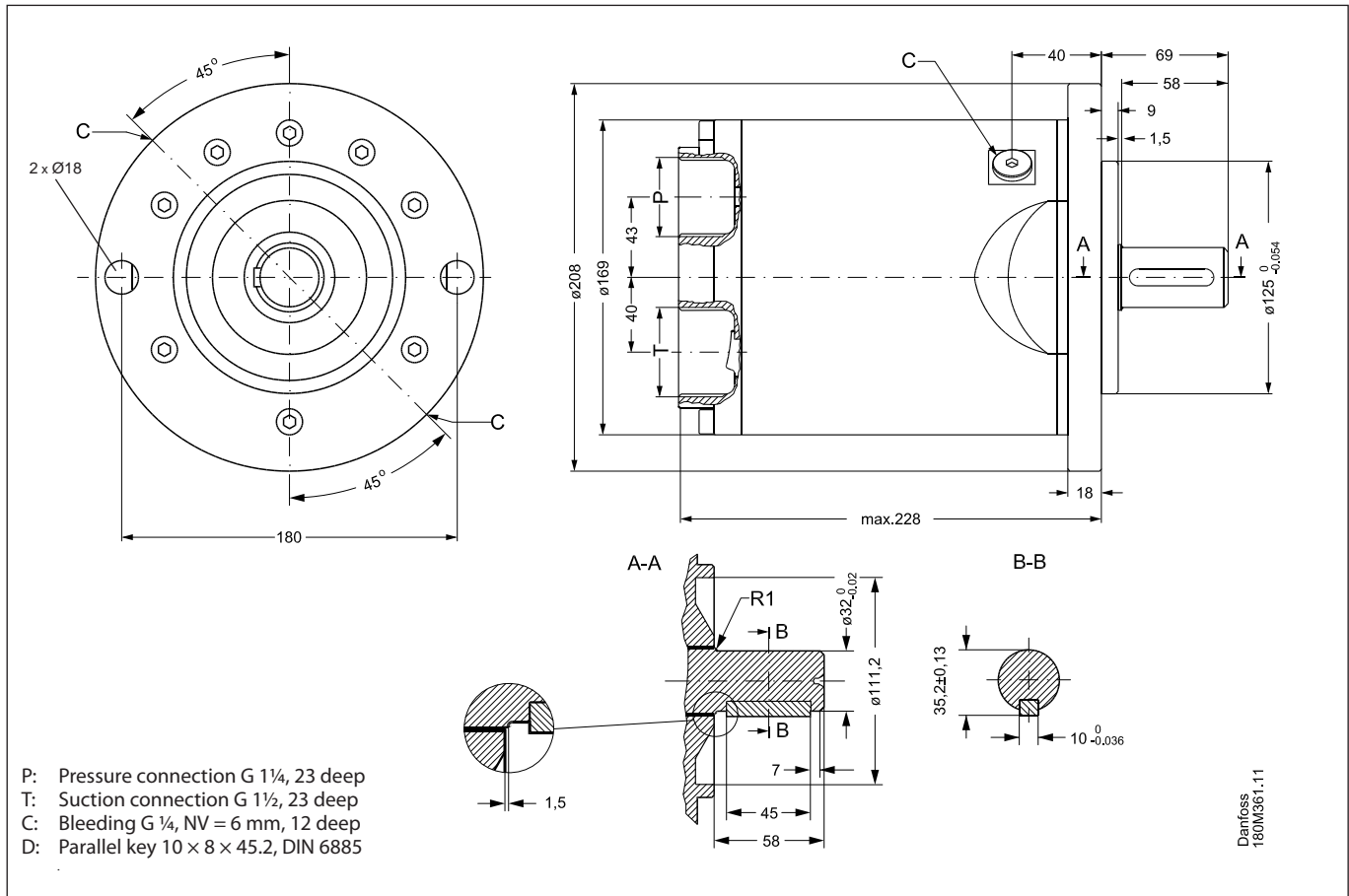

Danfoss can accept no responsibility for possible errors in catalogues, brochures and other printed material. Danfoss reserves the right to alter its products without notice. This also applies to products already on order provided that such alterations can be made without subsequential changes being necessary in specifications already agreed. All trademarks in this material are property of the respective companies. Danfoss and the Danfoss logotype are trademarks of Danfoss A/S. All rights reserved.



DK-6430 Nordborg
Denmark