

### 1. General information



The SWPE energy recovery unit consists of an APP pump and an APM motor, both connected to a double shafted electric motor. Energy recovery is obtained when high-pressure brine from the membranes is fed to the APM that converts the energy in the pressurized brine to mechanical energy to be re-used by the electric motor. As the APM has a fixed volumetric displacement, the recovery rate will be fixed.

APP pumps and APM motors are designed to supply low viscosity and corrosive fluids under high pressure, eg. in seawater reverse osmosis filtration applications and for high pressure salt water pumping.

The pumps and motors are based on the axial piston principle enabling a very light and compact design, and they are designed so that lubrication of the moving parts in the pumps and motors is provided by the fluid itself. No oil lubrication is thus required.

All parts included in the pumps and motors are designed to provide long service life, i.e. long service life with a constantly high efficiency and minimum of service required.

The pumps and motors are fixed displacement units in which the flow is proportional to the number of revolutions of the input shaft and the pump/motor displacement, regardless of any counter-pressure.

The electric motors are designed for driving equipment that requires continuous operation, and their high efficiency reduces energy consumption.

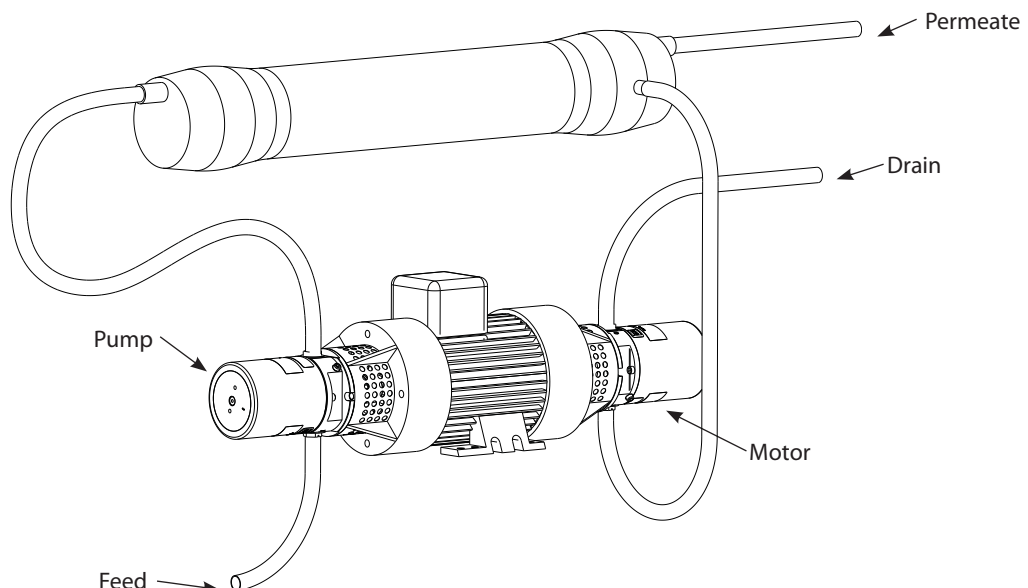

### 2. Benefits

- One of the smallest and lightest pumps/motors on the market.
- No preventive maintenance required (no periodic service like e.g. change of lubricant and wearing parts).
- Long service life. Danfoss guarantees 8000 hours maintenance-free operation.
- All parts of the pump and the motor are made of non corrosive materials eg. Duplex (SAF 2205/EN1.4462/UNS S31803-S32205) and Super-duplex (SAF 2507/EN1.4410/UNS S32750) stainless steel and carbon reinforced PEEK.
- High efficiency.
- The high efficiency of the electric motor saves money.

### 3. Technical data

APP pump / APM motor		APP1.0/APM0.8	APP1.5/APM1.2	APP1.8/APM1.2	APP2.5/APM2.0	APP2.5/APM1.8
<b>1450 rpm</b>						
Code number		180B8000	180B8002	180B8004	180B8006	180B8008
Feed flow	m <sup>3</sup> /h (gpm)	0.50 (2.2)	0.80 (3.5)	0.85 (3.7)	1.25 (5.5)	1.25 (5.5)
Recovery rate	%	29	28	32	29	32
Permeate (± 10%)	m <sup>3</sup> /h (gpm)	0.14 (0.6)	0.22 (1.0)	0.27 (1.2)	0.36 (1.6)	0.40 (1.8)
Electric motor (4 poles)		1.1 kW, IEC 90	1.5 kW, IEC 90	1.5 kW, IEC 90	2.2 kW, IEC 100	2.2 kW, IEC 100
<b>2900 rpm</b>						
Code number		180B8001	180B8003	180B8005	180B8007	180B8009
Feed flow	m <sup>3</sup> /h (gpm)	1.05 (4.6)	1.55 (6.8)	1.65 (7.3)	2.55 (11.2)	2.55 (11.2)
Recovery rate	%	29	28	32	29	32
Permeate (± 10%)	m <sup>3</sup> /h (gpm)	0.30 (1.3)	0.43 (1.9)	0.52 (2.3)	0.74 (3.3)	0.82 (3.6)
Electric motor (2 poles)		2.2 kW, IEC 90	3 kW, IEC 100	3 kW, IEC 100	*	*

If other flow or recovery rate is required, please contact Danfoss RO Solutions Sales Organization.

\* For this combination, please contact Danfoss RO Solutions Sales Organization.

### 4. Flow

Permeate production range

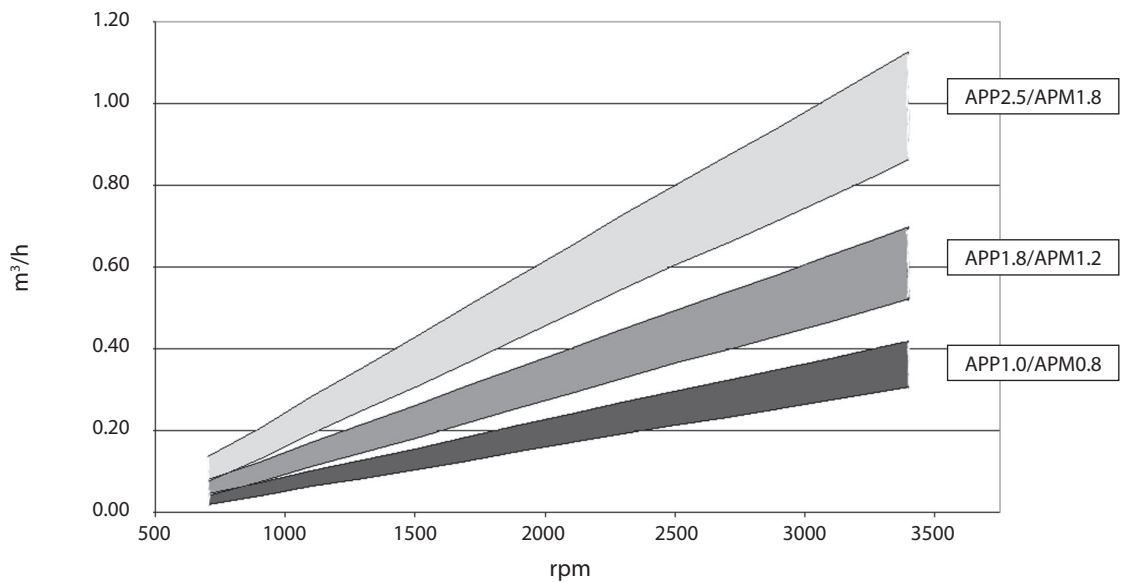

Permeate production range

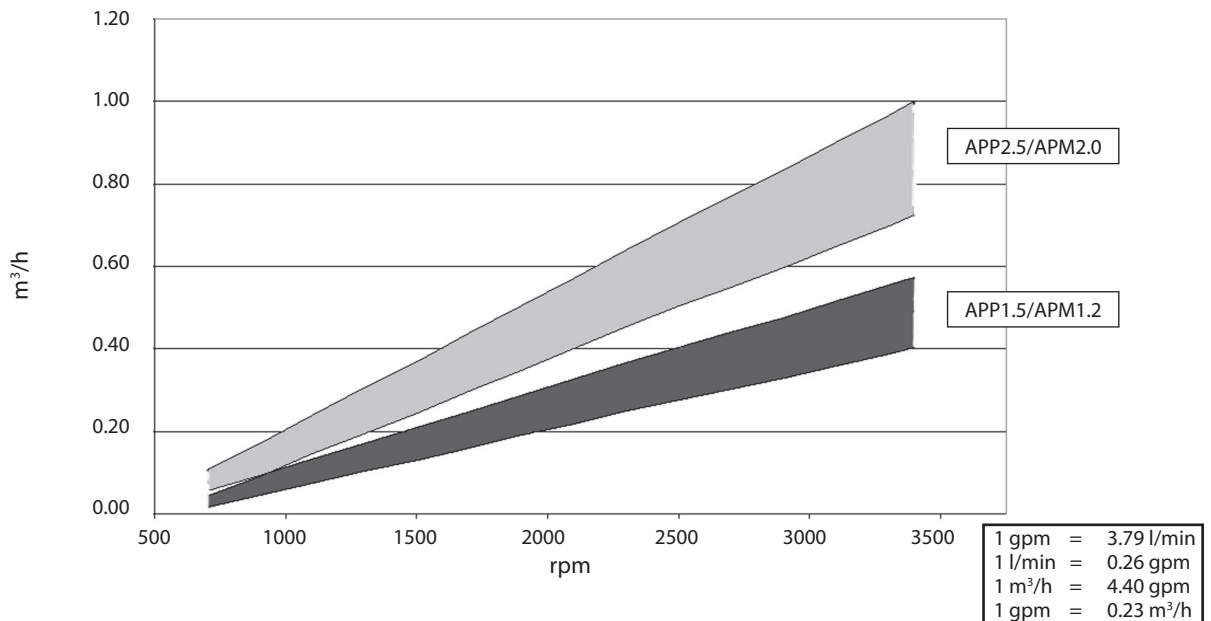

1 gpm = 3.79 l/min  
 1 l/min = 0.26 gpm  
 1 m<sup>3</sup>/h = 4.40 gpm  
 1 gpm = 0.23 m<sup>3</sup>/h

Due to tolerances of both the pumps and the motors of an SWPE unit, permeate production will vary according to the figures above.

## 5. Energy consumption vs. pressure

A variation of up to 20% may occur depending on the rpm and the efficiencies of the pump and the motor.

The curves below are calculated using an efficiency of the electric motor of 86% and provided that the pressure at the inlet of the APM motor is 1 bar less than the pressure from the APP pump.

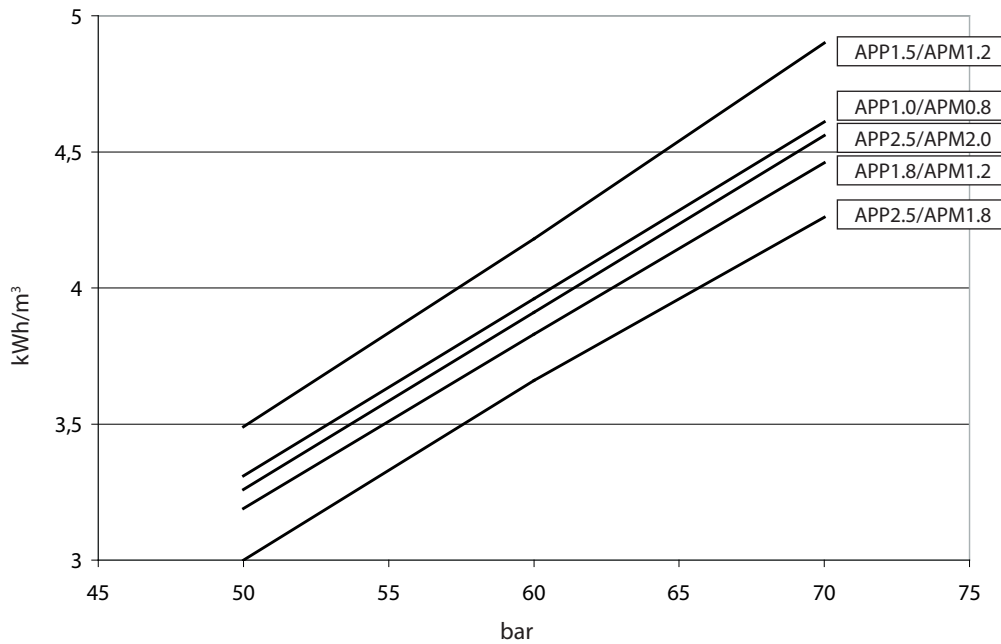

## 6. Power consumption

SWPE unit		APP1.0/APM0.8	APP1.5/APM1.2	APP1.8/APM1.2	APP2.5/APM2.0	APP2.5/APM1.8
Recovery rate (%)		29	28	32	29	32
kWh @	50 bar (725 psi)   1450 rpm	0.6	0.9	0.9	1.4	1.5
	50 bar (725 psi)   2900 rpm	1.2	1.7	1.9	2.8	3.0
	60 bar (870 psi)   1450 rpm	0.7	1.0	1.2	1.7	1.5
	60 bar (870 psi)   2900 rpm	1.5	2.1	2.3	3.4	3.5
	70 bar (1015 psi)   1450 rpm	0.8	1.2	1.3	2.0	2.1
	70 bar (1015 psi)   2900 rpm	1.7	2.4	2.7	3.8	4.0

The figures in the table above are calculated using an efficiency of the electric motor of 86% and provided that the pressure at the inlet of the APM motor is 1 bar less than the pressure from the APP pump.

1 hp hr = 0.75 kWh
1 kWh = 1.34 hp hr

## 7. Pressure

### 7.1 Inlet pressure

- 7.1.1 APP pump: The pressure at the pump inlet (I) must be in the range: 0.5 - 5 bar (7.3 - 72.5 psi).  
 7.1.2 APM motor: The pressure at the motor inlet (I) must be in the range: 10 - 80 bar (145 - 1160 psi).

### 7.2 Outlet pressure

- 7.2.1 APP pump: The pressure at the pump outlet (O) must be in the range: 20 - 80 bar (290 - 1160 psi).  
 7.2.2 APM motor: The pressure at the motor outlet (O) must be in the range: 0.5 - 5 bar (7.3 - 72.5 psi).

## 8. Temperature and corrosion

### 8.1 Operation:

- Fluid temperature: +3°C to +50°C (+37.4°F to 122°F) - dependent on the NaCl concentration
- Ambient temperature: +3°C to +50°C (+37.4°F to 122°F)

The chart below illustrates the corrosive resistance of different types of stainless steel related to NaCl concentration and temperature.

All critical parts of the APP water pump and the APM water motor are made of SAF 2507.

If the APP/APM are operated at high salinity, always flush the APP/APM with fresh water at operation stop in order to minimise the risk of crevice corrosion.

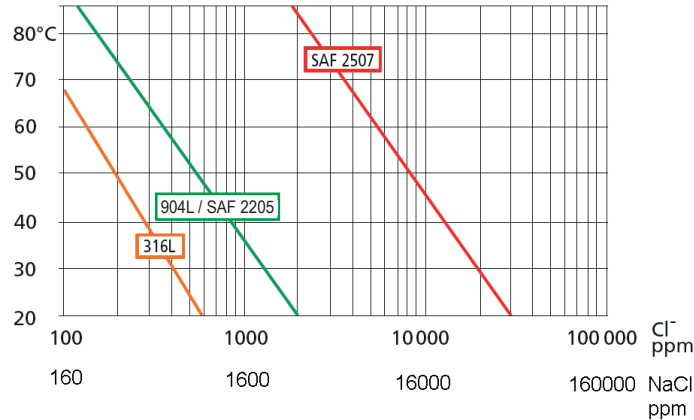

NaCl vs. temperature

### 8.2 Storage:

- Storage temperature: -40°C to +70°C (+37.4°F to 122°F) – provided that the APP/APM is drained of fluid and stored “plugged”.

Antefreeze protection is required at temperatures below 2°C. Danfoss recommends using Dowcal N from Dow Chemical Company or Chillsafe mono propylene glycol from Arco Chemical Company.

## 9. Noise level

The noise from the SWPE unit is typically less than 80 dB(A).

Generally, noise will be reduced if speed is reduced and vice versa. Use flexible hoses in order to minimize vibrations and noise.

Since the pump/motor typically is mounted on a bell housing or frame, the noise level can only be determined for the complete unit (system).

It is therefore very important that the pump/motor is mounted correctly on a frame with dampers to minimize vibrations and noise.

The noise level is influenced by:

- The speed of the pump/motor, high rpm create more noise than low rpm
- Rigid mounting of the pump/motor generates more noise than flexible mounting
- Pipe mounting direct to the pump/motor increases the noise level compared to a flexible hose

## 10. Filtration

As water has very low viscosity, the APP pumps / APM motors have been designed with very narrow clearance in order to control internal leakage rates and improve component performance. Therefore it is important that the inlet water is filtered properly to minimize the wear of the pump/motor.

The main filter must have a filtration efficiency of 99.98% at 10 µm. We recommend that you use precision depth filter cartridges rated 10µm abs.  $\beta_{10} > 5000$  (equivalent to a filtration efficiency of 99.98%). Bag filters and string wound filter cartridges typically have only 90% filtration efficiency. This means that for each 100,000 particles reaching the filter, 10,000 particles pass through it compared to only 20 particles in a filter with an efficiency of 99.98%.

For more information on the importance of proper filtration, please consult our publication “Filtration” (code number 521B0861), which also will provide you with an explanation of filtration definitions and a guidance on how to select the right filter.

# 11. Dimensions

## 11.1 Pump/motor

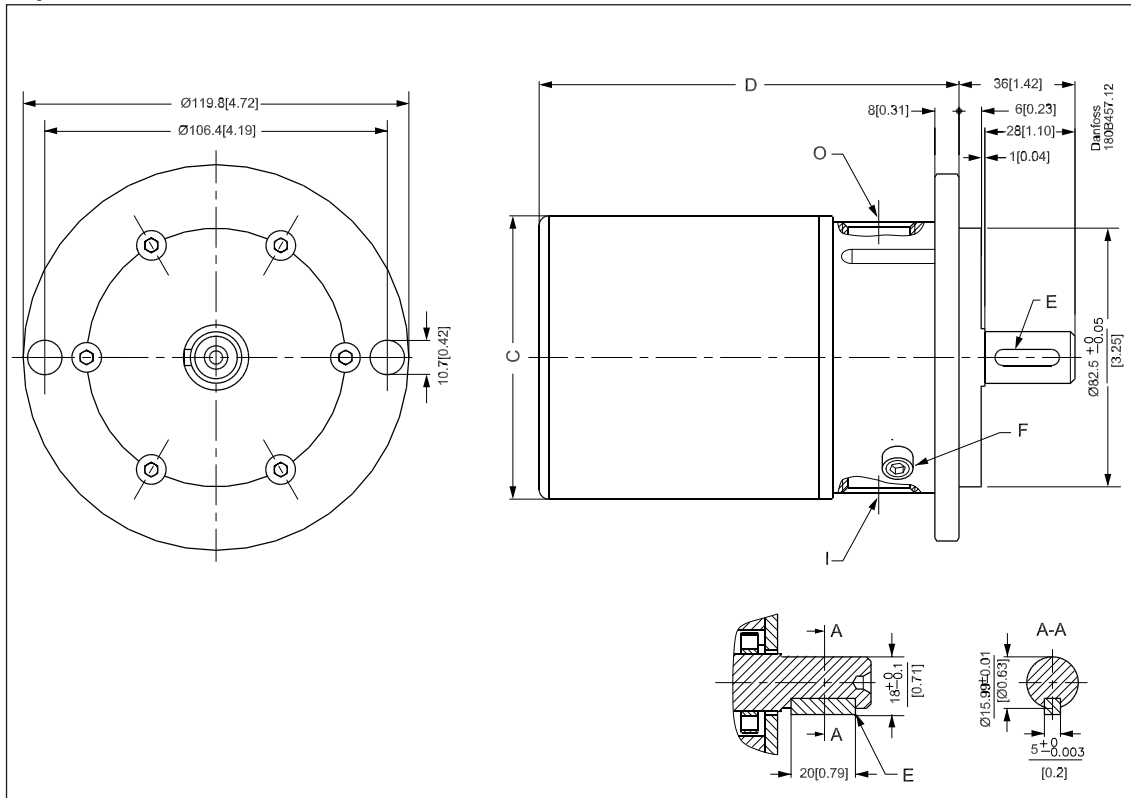

Description	Pump Motor	APP0.6 and APP1.0	APP1.5, APP1.8, APP2.2 and APP2.5
		APM0.8 and APM1.2	APM1.8 and APM2.0
C	mm (in)	Ø 88 (3.5)	Ø 105 (4.1)
D	mm (in)	131 (5.2)	166 (6.5)
E	Parallel key, DIN 6885, mm (in)	5 × 5 × 20 (0.20 × 0.20 × 0.78)	5 × 5 × 20 (0.20 × 0.20 × 0.78)
F	Bleeding	M6, Hexagon AF = 5 mm	M6, Hexagon AF = 5 mm
I	Inlet connection	<u>Pump</u> : BSP G½"; 15 (0.59) deep	<u>Pump</u> : BSP G¾"; 15 (0.59) deep
		<u>Motor</u> : BSP G½"; 15 (0.59) deep	<u>Motor</u> : BSP G½"; 17 (0.67) deep
O	Outlet connection	<u>Pump</u> : BSP G½"; 15 (0.59) deep	<u>Pump</u> : BSP G½"; 17 (0.67) deep
		<u>Motor</u> : BSP G½"; 15 (0.59) deep	<u>Motor</u> : BSP G¾"; 15 (0.59) deep
Pump/motor mounting flange		SAE A 2	SAE A 2

## 11.2 Complete unit

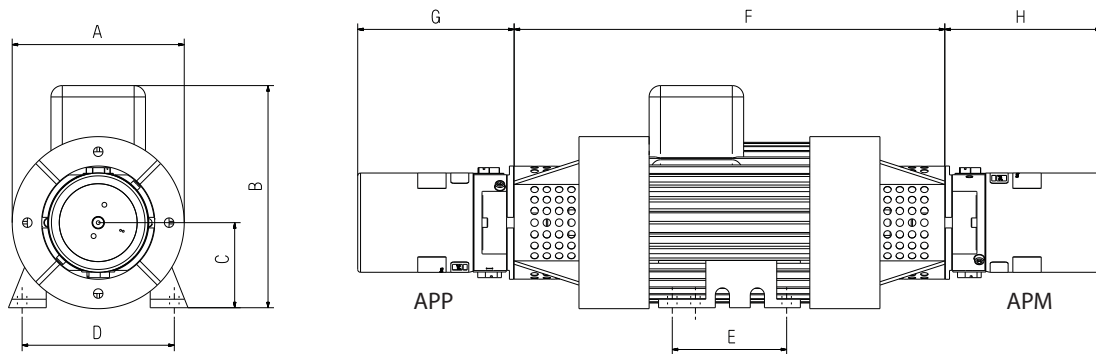

Pump/motor	rpm	A (mm)	B (mm)	C (mm)	D (mm)	E (mm)	F (mm)	G (mm)	H (mm)	IEC Electric motor
APP1.0/APM0.8	1450	190	220	90	140	100	460	131	131	1.1 kW, IEC 90-4
APP1.5/APM1.2	1450	190	220	90	140	125	460	166	131	1.5 kW, IEC 90-4
APP1.8/APM1.2	1450	190	220	90	140	125	460	166	131	1.5 kW, IEC 90-4
APP2.5/APM2.0	1450	210	240	100	160	140	560	166	166	2.2 kW, IEC 100-4
APP2.5/APM1.8	1450	210	240	100	160	140	560	166	166	2.2 kW, IEC 100-4
APP1.0/APM0.8	2900	190	220	90	140	125	460	131	131	2.2 kW, IEC 90-2
APP1.5/APM1.2	2900	210	240	100	160	140	560	166	131	3 kW, IEC 100-2
APP1.8/APM1.2	2900	210	240	100	160	140	560	166	131	3 kW, IEC 100-2

## 12. Installation

### 12.1 Mounting

The figure below illustrates how to mount the pump and the motor and connect them to electric motor/combustion engine.

- A: Flexible coupling
- B: Bell housing
- C: Motor shaft

If alternative mounting is required, please contact Danfoss Sales Organization for further information. To ensure easy mounting of the flexible coupling without using tools, the tolerances must be dimensioned accordingly.

**Note: Any axial and/or radial loads on the shaft must be avoided, see "User guide" (521B0888).**

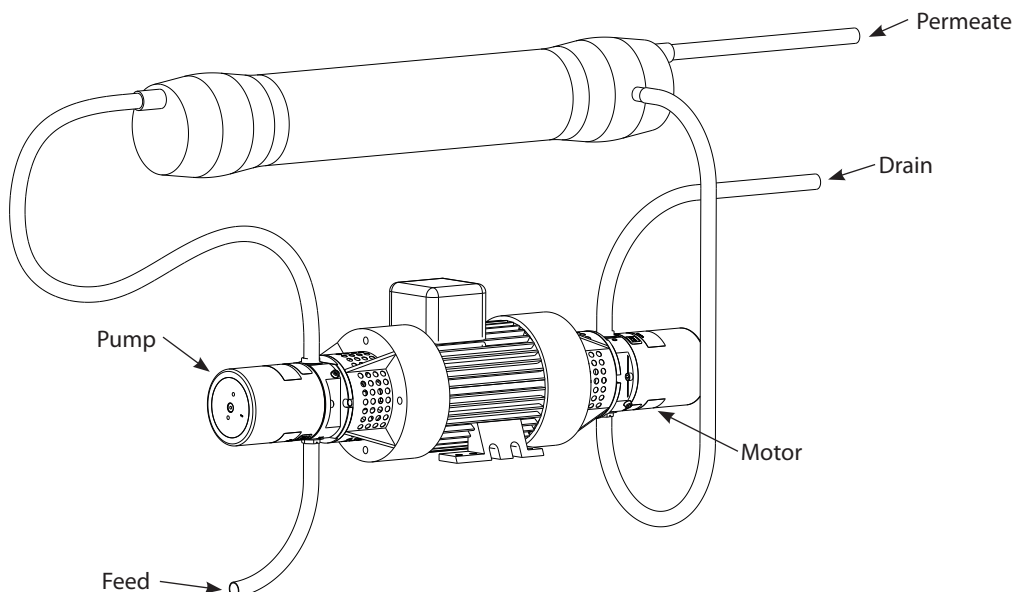

The pump/motor discharge should be connected to the rest of the plant with flexible high-pressure hoses.



## 14. Service

Provided that the pump/motor has been running according to the Danfoss specifications on pre-filtration, pressure, and rotation speed, Danfoss guarantees 8000 hours service-free operation, after which Danfoss recommends a pump/motor inspection where any worn parts must be replaced, in order to prevent a total and disastrous breakdown.

**Note: It is always recommended to replace pistons and shaft sealing if another service-free period is to be obtained.**

If the pistons are not replaced, more frequent inspection is recommended.

The APP pump and the APM motor are made of duplex/super duplex materials with fine corrosion properties. However, **it is always recommended to flush the pump/motor when the system is shut down.**

At high TDS and high water temperature, the service life of the shaft sealing will be reduced. For these applications it is recommended to replace the shaft sealing after approx. 4000 hours operation.

### 14.1 Periodic maintenance

Water acts as lubricant in the APP/APM. Thus there is no oil in the the pump/motor.

By operation below the curve for SAF 2507 in the figure in section 8.1, no parts are expected to be replaced within the first 8000 hours of operation.

It is recommended to inspect the internal parts of the APM after 4000 hours of operation, due to the high salinity of the received media.

### 14.2 Repair

In case of irregular function of the APP/APM, please contact the Danfoss RO Solutions Sales Organisation.

Danfoss can accept no responsibility for possible errors in catalogues, brochures and other printed material. Danfoss reserves the right to alter its products without notice. This also applies to products already on order provided that such alterations can be made without subsequential changes being necessary in specifications already agreed. All trademarks in this material are property of the respective companies. Danfoss and the Danfoss logotype are trademarks of Danfoss A/S. All rights reserved.



DK-6430 Nordborg  
Denmark