

VLT® High Power Drive Dimensions

D1 frame (floor or wall mount)

Inches (mm)

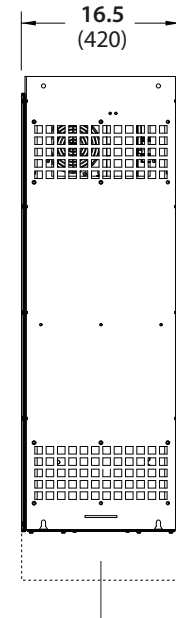
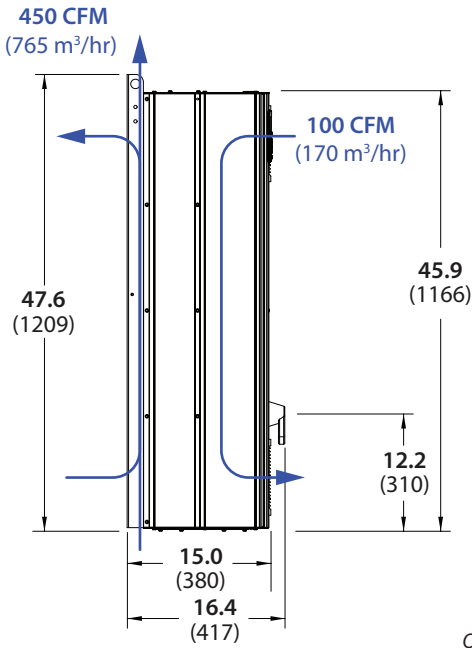
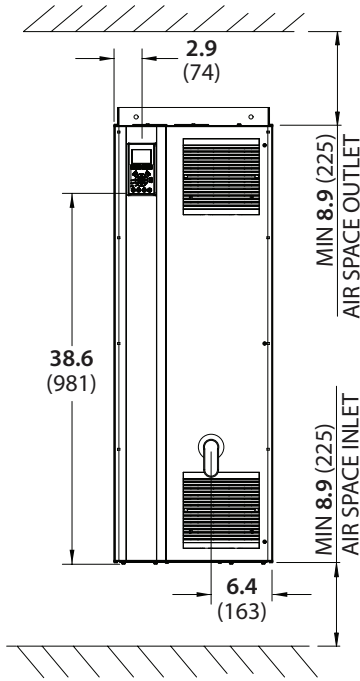

Optional pedestal 176F1827 available for standalone floor mount installations (adds 7.9"/200mm to height)

D2 frame (floor or wall mount)

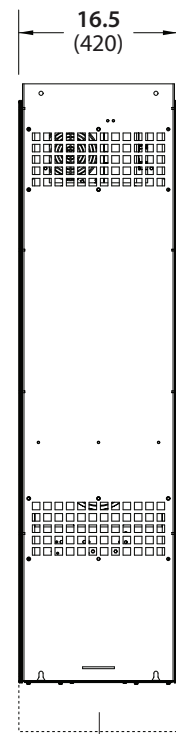
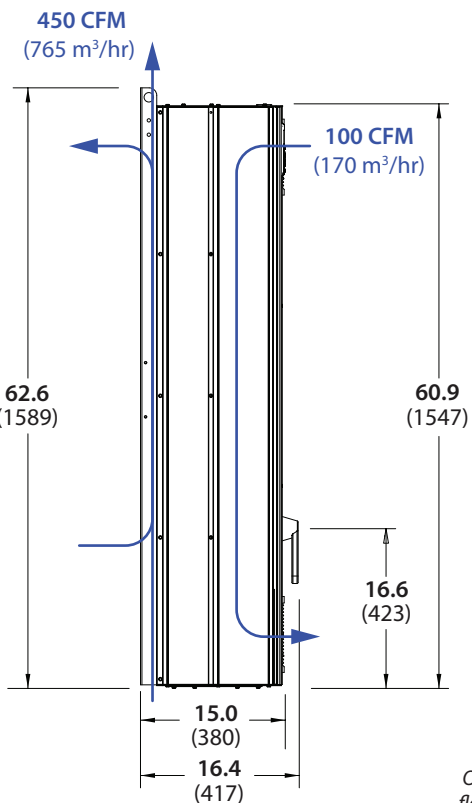
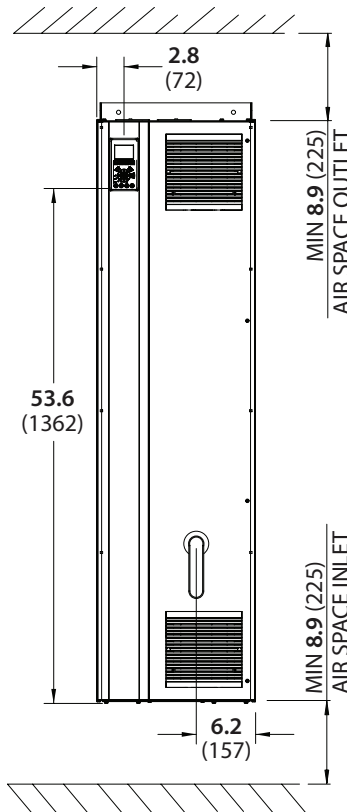

Optional pedestal 176F1827 available for standalone floor mount installations (adds 7.9"/200mm to height)

Drives shown with optional disconnect switch

VLT® High Power Drive Dimensions

D3 frame (cabinet mount)

Inches (mm)

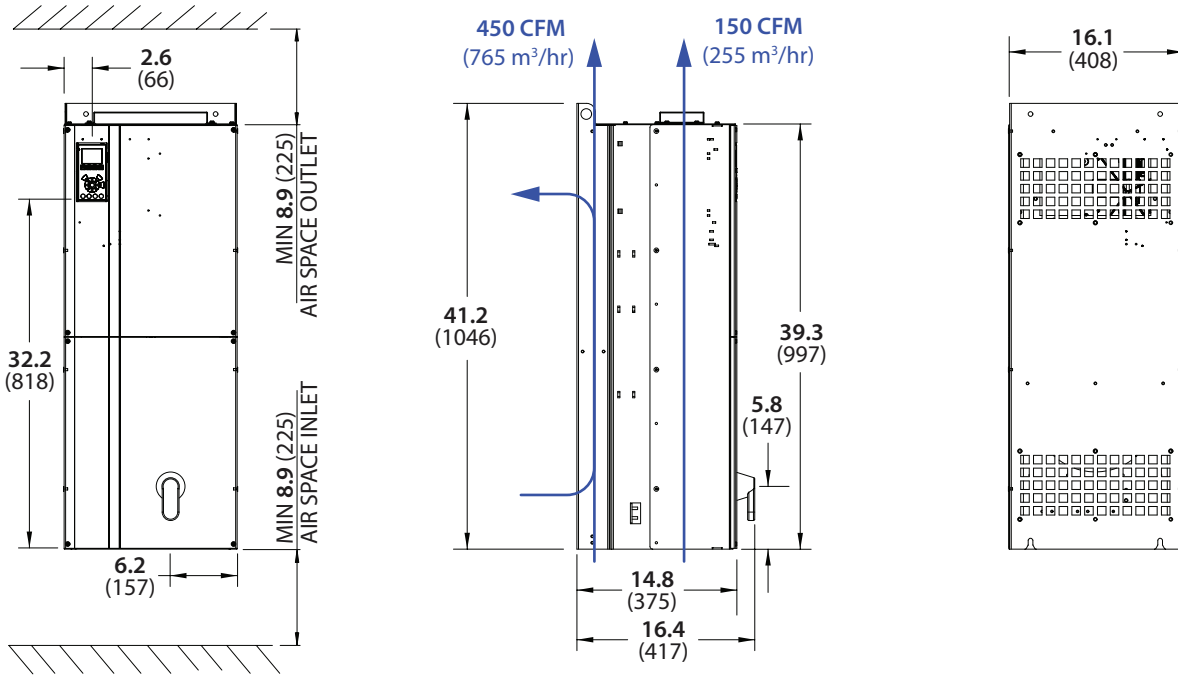

D4 frame (cabinet mount)

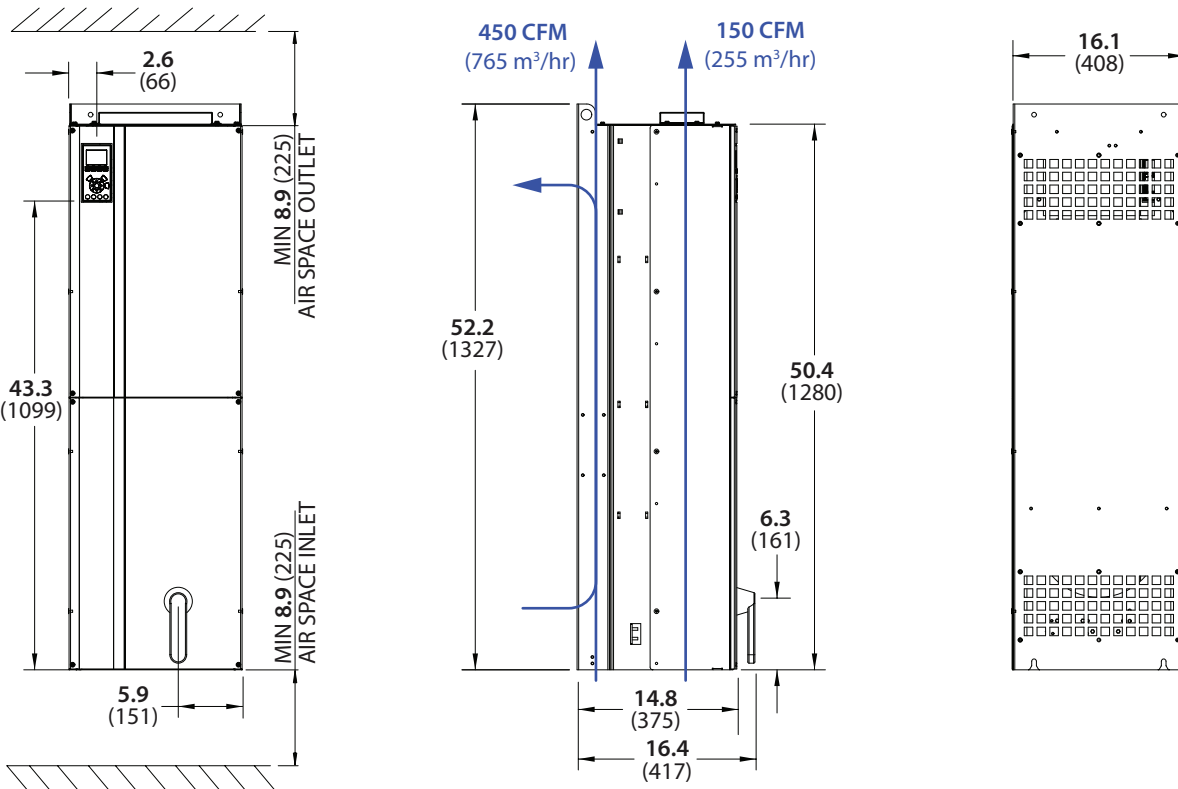

Drives shown with optional disconnect switch

VLT® High Power Drive Dimensions

E1 frame (floor mount)

Inches (mm)

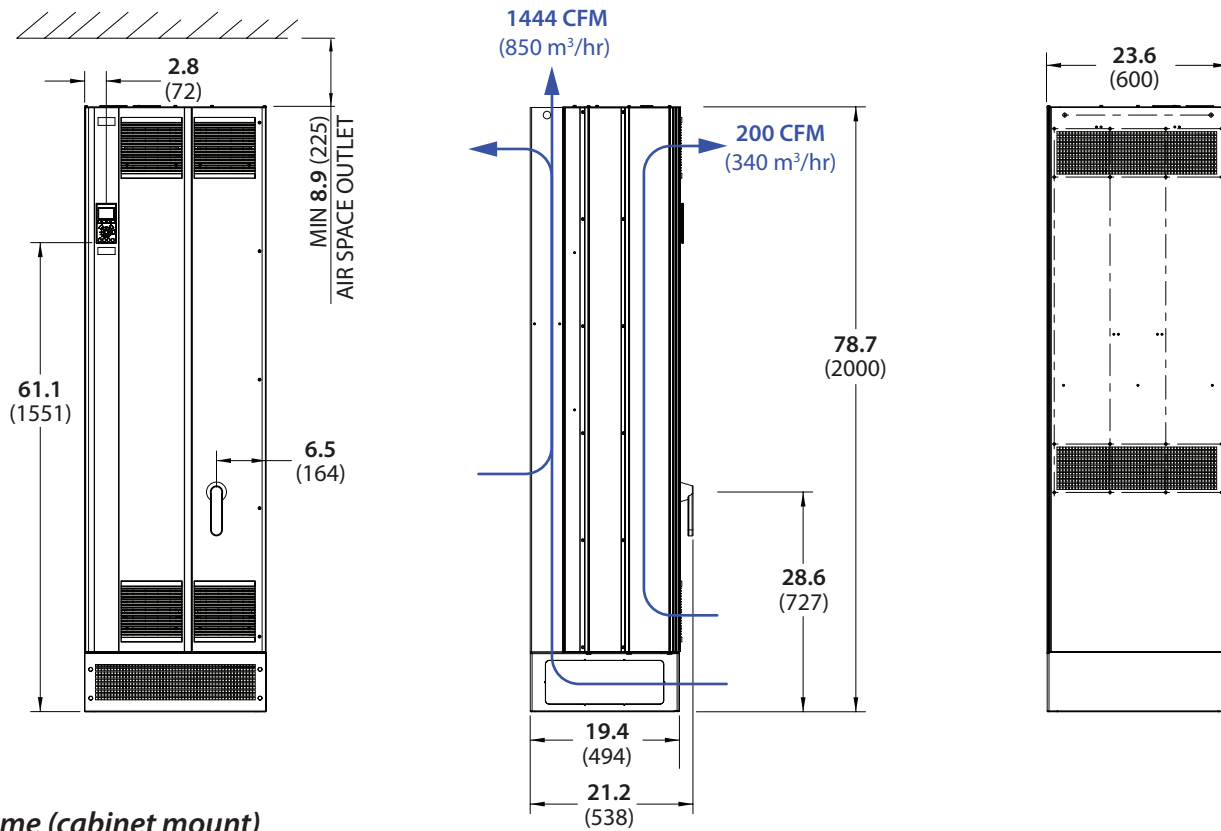

E2 frame (cabinet mount)

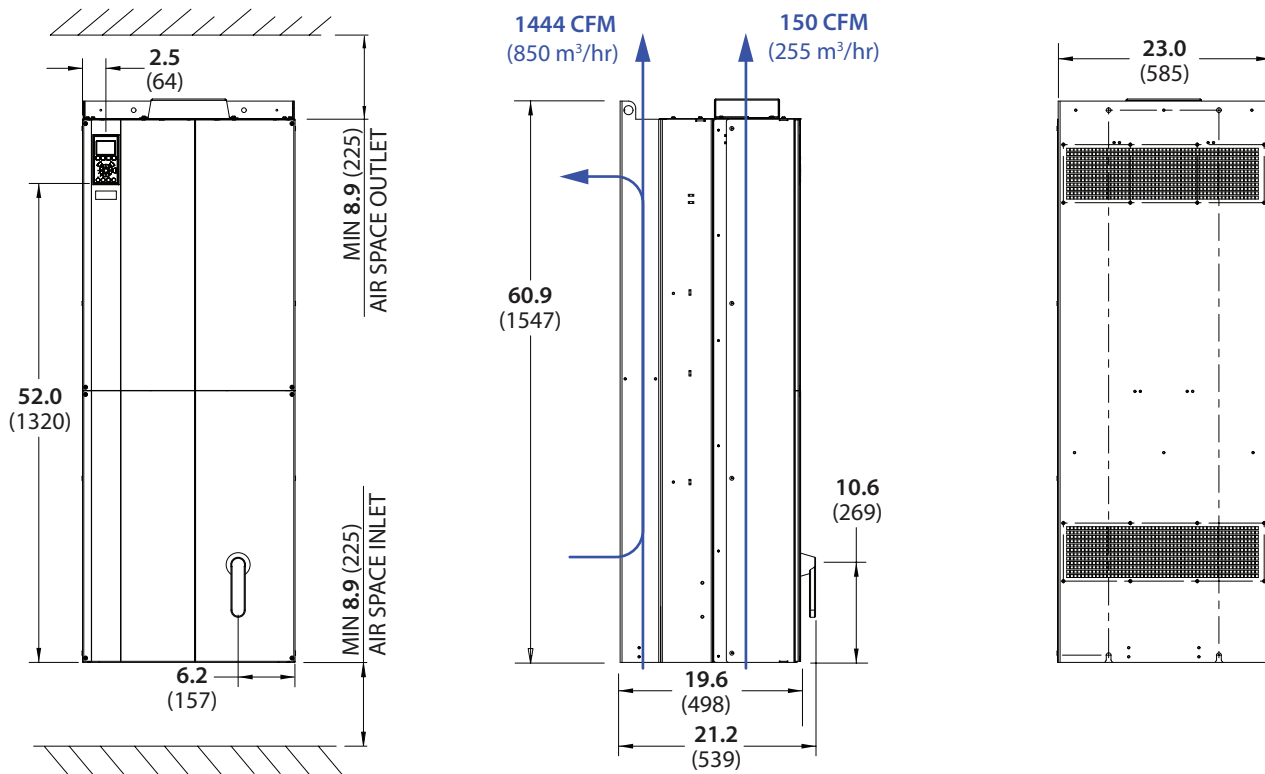

Drives shown with optional disconnect switch

VLT® High Power Drive Dimensions

F1 frame (floor mount)

Inches (mm)

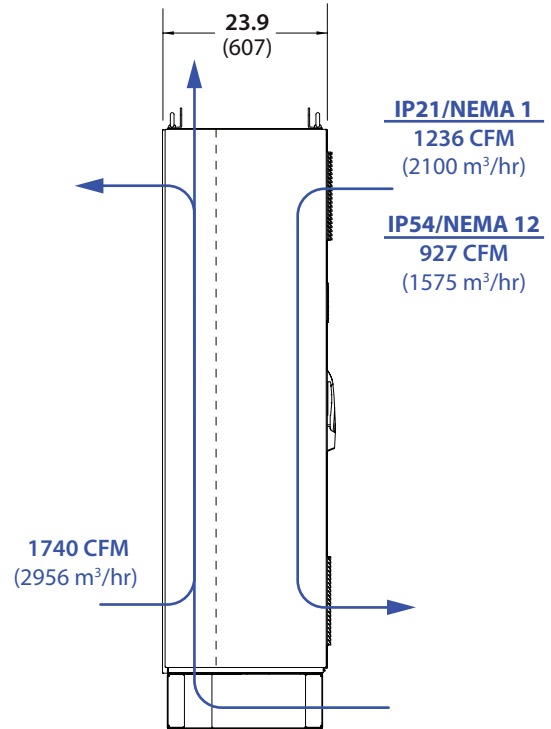
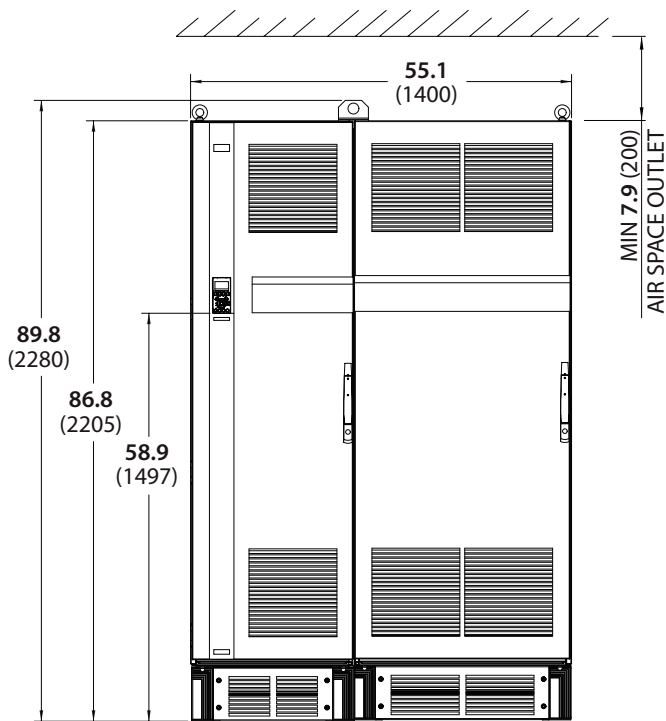

F2 frame (floor mount)

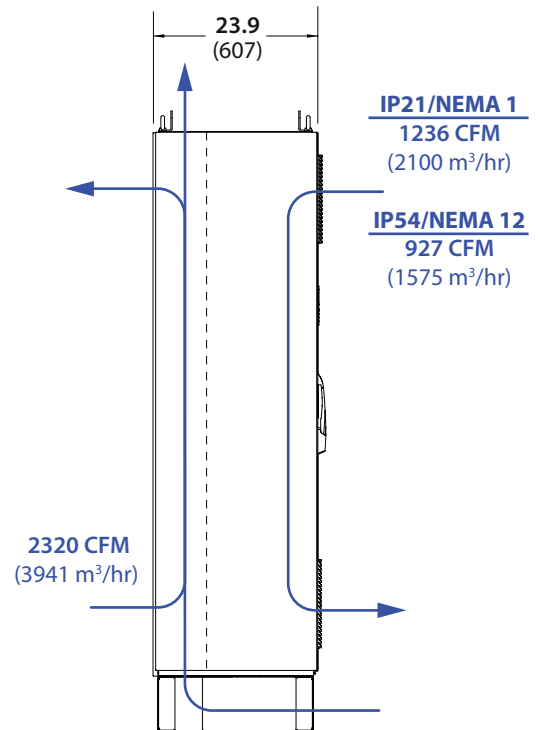
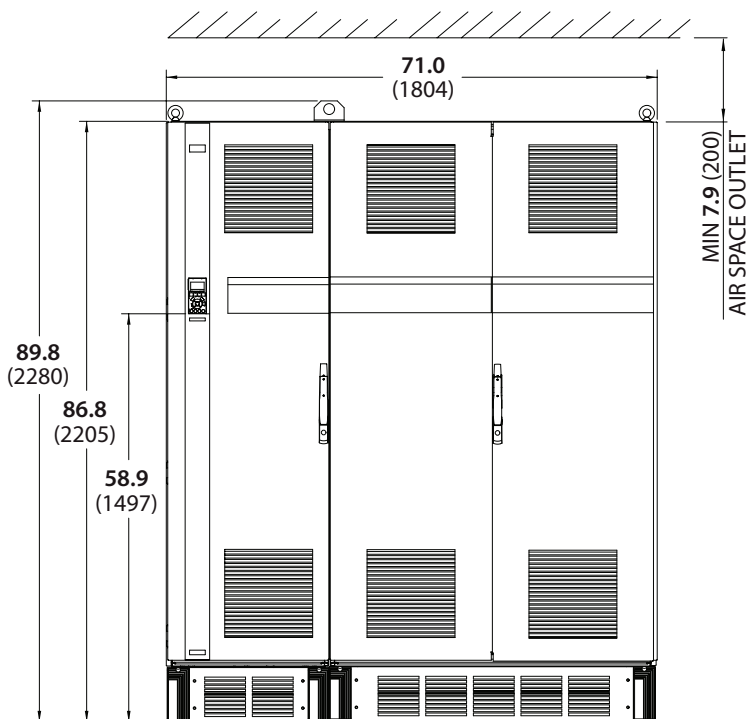

Drives shown with optional disconnect switch

VLT® High Power Drive Dimensions

F3 frame (floor mount)

Inches (mm)

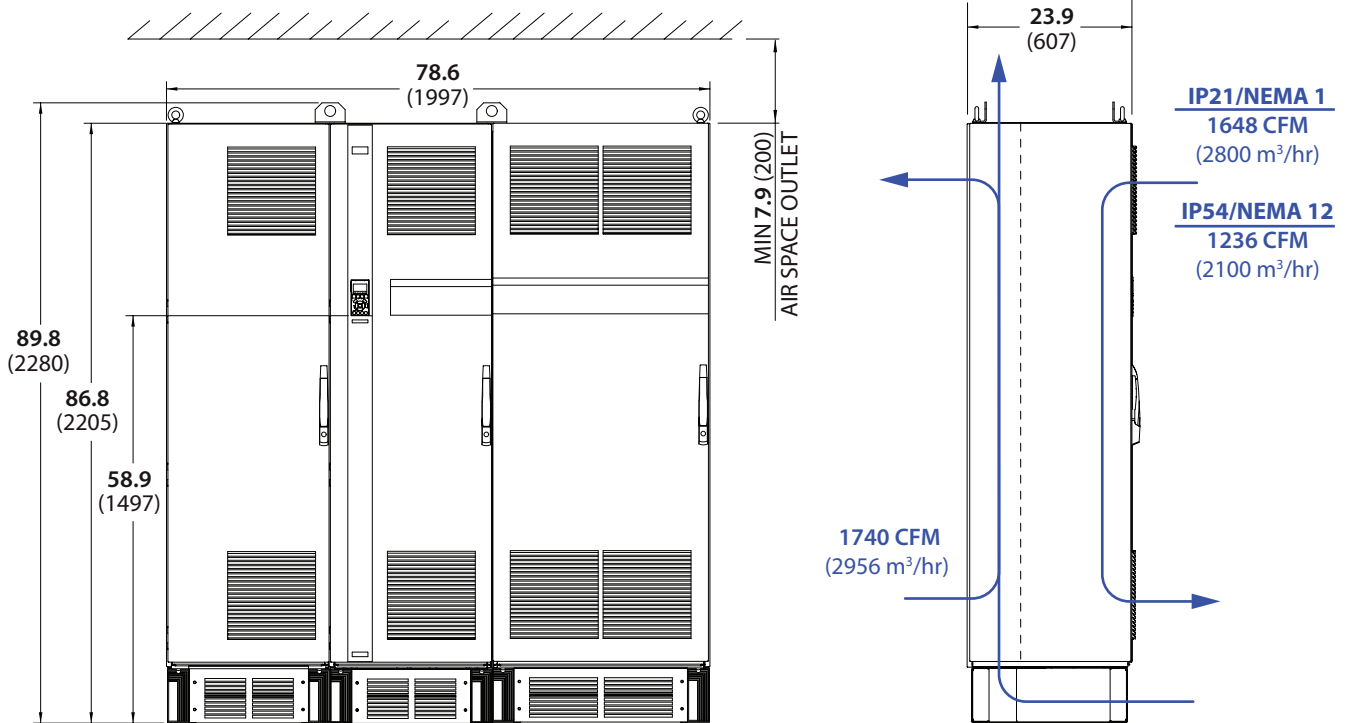

F4 frame (floor mount)

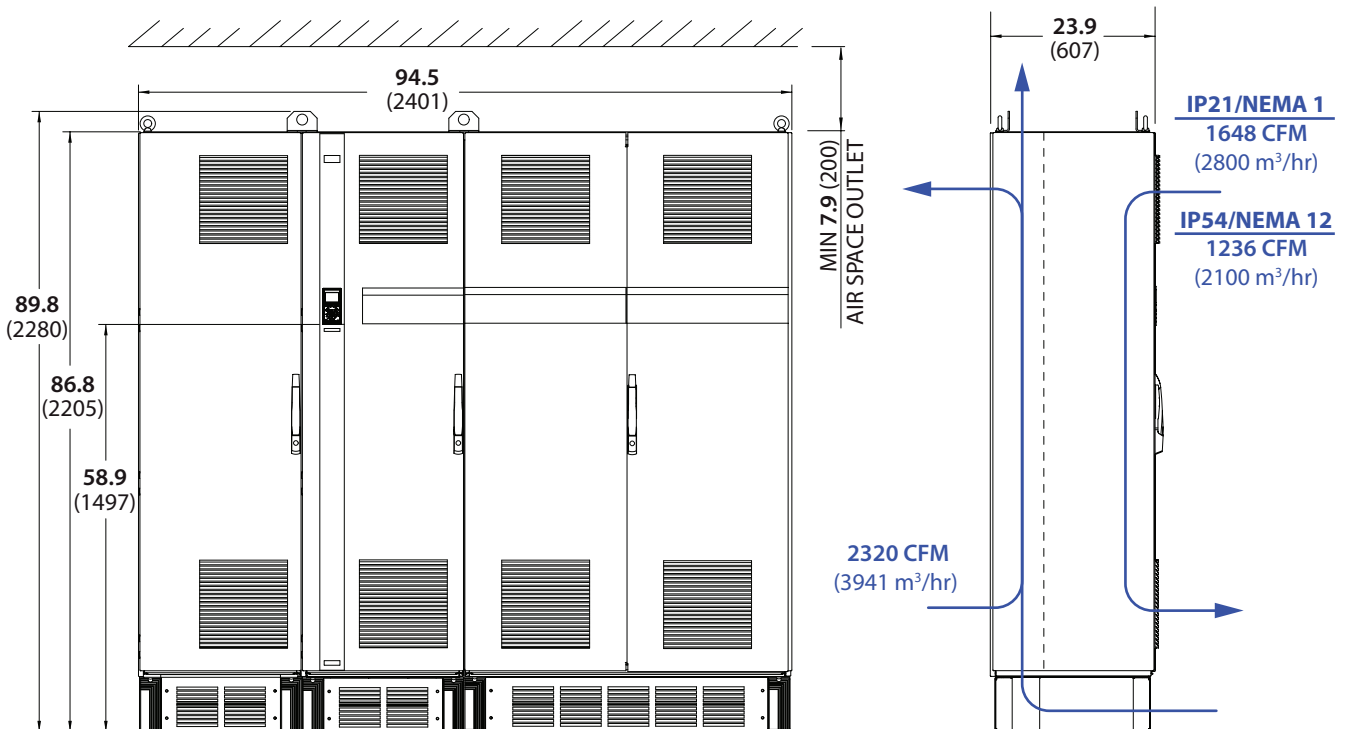

Drives shown with optional disconnect switch