

Document Version Number 5**Software Version 2.0****Table of Contents**

Chapter 1	Introduction	
	Getting Started	3
	Receiving, Inspection, and Storage	4
	Nameplate Information	4
	General Technical Data	5
	Specifications	8
	External Parts and Labels	9
Chapter 2	Installation and Wiring	
	Installation Requirements	10
	Wiring	11
	Installation without RFI-filter	12
	EMC-correct installation with RFI-filter	13
	Use of EMC compliant cables	14
	Earthing of screened/armoured control cables	15
	Control Terminal Designations (Factory Settings)	16
	Safety Precautions	17
Chapter 3	Digital Keypad/Display Operation	
	Digital Keypad/Display Features	19
	Quick Set-up	21
	Operation	23
Chapter 4	Description of Parameters	25
Chapter 5	Summary of Parameters	69
Chapter 6	Troubleshooting and Fault Information	76
Appendix A	Dimensions	80
Appendix B	Accessories	84
Appendix C	CE Labeling	86
Appendix D	Serial Communication	88

VLT is a registered Danfoss trade mark

Danfoss can accept no responsibility for possible errors in catalogs, brochures and other printed material. Danfoss reserves the right to alter its products without notice. This also applies to products already on order provided that such alterations can be made without subsequential changes being necessary in specifications already agreed.

Chapter 1

Introduction

Congratulations on your purchase of a VLT® Adjustable Frequency Drive. The VLT® MICRO is a high-performance / low noise general-purpose drive, manufactured using the highest quality components and incorporating the latest micro-processor technology and control algorithms. The purpose of this chapter is to provide specific yet simple information to unpack, install, and operate the drive. This chapter contains information on the following:

- Getting Started
- Unpacking, Inspection, and Storage
- Nameplate Information
- Identification of Parts

Getting Started

This manual will help in the installation, parameter setting, troubleshooting, and daily maintenance of the AC drive. To guarantee safe operation of the equipment, read the following safety guidelines before connecting the Adjustable Frequency Drive to AC Power.



WARNING

The VLT Adjustable Frequency Drive (AFD) contains dangerous voltages when connected to line voltage. After disconnecting from the line wait at least one minute before touching any electrical components. Only a competent electrician should carry out the electrical installation. Improper installation of the motor or the AFD may cause equipment failure, serious injury or death. Follow this manual, National Electrical Codes (NEC®) and local safety codes.



WARNING

Electrostatic Precaution; Electrostatic discharge (ESD). Many electronic components are sensitive to static electricity. Voltages so low that they cannot be felt, seen or heard, can reduce the life, affect performance, or completely destroy sensitive electronic components. When performing service, proper ESD equipment should be used to prevent possible damage from occurring.



CAUTION

It is the responsibility of the user or the person installing the AFD to provide proper grounding, as well as motor overload and branch circuit protection according to the National Electrical Code (NEC®) and local codes.



NB!

Since the leakage current is > 3.5 mA, reinforced earthing must be established, as this is required to ensure compliance with EN 50178. Never use ELCB relays (type A) that are not suitable for DC fault currents from 3-phase rectifier loads.

If ELCB relays are used, they must be:

- Suitable for protecting equipment with a DC content in the faulty current (3-phase bridge rectifier)
- Suitable for a pulse-shaped, brief discharge on power-up
- Suitable for a high leakage current (300mA)

Receiving, Transporting, Inspecting, and Storage

This VLT® MICRO Adjustable Frequency Drive has gone through rigorous quality control tests at the factory before shipment. After receiving and before transporting the drive, check for the following.

Receipt

After receiving the AC drive, inspect the unit to insure it was not damaged during shipment.

Transportation

Climatic condition : Class 2K3

Inspection

- After unpacking the unit, make sure that the package includes a drive unit and the Instruction Manual.
- Make sure that the part number indicated on the nameplate and packing carton corresponds with the part number of your order.

Storage

The AFD should be kept in the shipping carton before installation. In order to retain the warranty coverage, the drive should be stored properly. Some storage recommendations are:

- Store in a clean, dry place
- Store within an ambient temperature range of -20°C to +65°C
- If possible, store in an air-conditioned environment where the relative humidity is less than 95%, non-condensing.
- Do not store the unit in places where it could be exposed to corrosive gases.
- Do not store the unit on an unstable surface where it could be damaged by falling to the floor.

Nameplate Information

Example for 1HP 240V AC Adjustable Frequency Drives

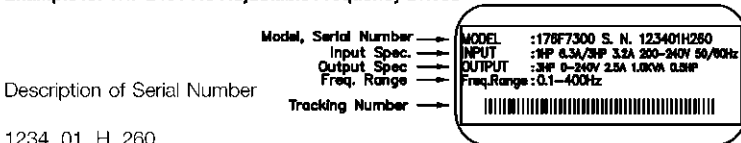

Description of Serial Number

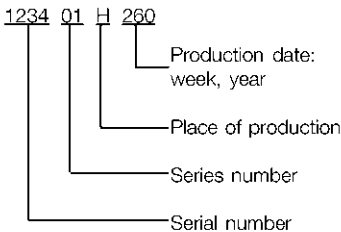

Part Numbers:

1/2HP	230V single phase/three phase	176F7300
1HP	230V single phase/three phase	176F7301
2HP	230V single phase/three phase	176F7302
1/2HP	230V single phase/three phase CE	176F7306
1HP	230V single phase/three phase CE	176F7307
2HP	230V single phase/three phase CE	176F7308
1HP	460V three phase CE	176F7312
2HP	460V three phase CE	176F7313
3HP	460V three phase CE	176F7314
3HP	230V single phase/three phase CE	176F7330
5HP	230V three phase CE	176F7331
5HP	460V three phase CE	176F7332

General Technical Data

AC line supply (L1, L2, L3):

Supply voltage 200-240 V units	1 x 200/208/220/230/240 V ±10%
Supply voltage 200-240 V units	3 x 200/208/220/230/240 V ±10%
Supply voltage 380-480 V units	3 x 380/400/415/440/460/480 V ±10%
Supply frequency	50/60 Hz
Max. imbalance of supply voltage	±2% of rated supply voltage
Power factor/cos φ	0.90/1.0 at rated load
Max short circuit rating	5000 A

VLT output data (U, V, W):

Output voltage	0-100% of supply voltage
Output frequency	0.1 - 400 Hz
Rated motor voltage, 200-240 V units	200/208/220/230/240 V
Rated motor voltage, 380-480 V units	380/400/415/440/460/480 V
Rated motor frequency	50/60 Hz
Switching on output	Protected
Ramp times	0.1-600 sec.

Torque characteristics:

Starting torque	150% for 1 min.
Acceleration torque	100%
Overload torque, 200-240 V	150% for 1 min.

Control card, digital inputs:

Number of programmable digital inputs	6
Terminal nos.	M0, M1, M2, M3, M4, M5

Control card, analog inputs:

No. of programmable analog inputs (selectable voltage or current)	1
Terminal numbers	AV 1
Voltage level	0 - 10 VDC
Input resistance, R_i	approx. 47 k Ω
Current range	4-20 mA
Input resistance, R_i	approx. 250 Ω
Resolution	10 bit + sign

Galvanic isolation: All analog inputs are galvanically isolated from the supply voltage.

Control card, 10 VDC supply:

Terminal numbers	+10V
Max. load	10 mA

Control card, analog outputs:

Number of programmable analog outputs	1
Terminal numbers	AFM
Voltage range at analog output	0 - 10 VDC

Galvanic isolation: All analog outputs are galvanically isolated from the supply voltage.

PHC output

Number of programmable photocoupler outputs	1
Terminal numbers	MO1-MCM
Max. output	-48 VDC, 50 mA

Control card, RS-485 serial communication:

Terminal numbers	RJ-11
------------------------	-------

Relay outputs:

No. of programmable relay outputs	1
Terminal numbers	RA, RC (N.O.) RB, RC (N.C.) (Form C)
Max. terminal load rating	120 VAC/28 VDC, 5 A
.....	240 VAC, 2.5 A

Brake resistor terminals:

Terminal numbers.....	B1, B2
-----------------------	--------

Cable lengths and cross-sections:

Use 75° grade copper wire minimum

Max. motor cable length	50 m
Max. cable cross-section for line, motor and brake	14 AWG (2.0 mm ²)
Max. cable cross-section for control terminals	14 AWG (2.0 mm ²)

Control characteristics:

Frequency range	0.1 - 400 Hz
Resolution on output frequency	±0.1 Hz
Speed, control range (open loop).....	1:20 of synchro. speed
Speed, accuracy (open loop)	< 1800 rpm: max. error 2%
.....	> 1800 rpm: max. error of 0.5% of actual speed

Environment:

Enclosure	Protected chassis (IP20)
Vibration test	1.0 g less than 20Hz, 0.6 g 20-50Hz
Max. relative humidity	less than 90% (non-condensing)
Ambient temperature	-10°C - +50°C
Temperature during storage/transport	-20 - +60°C
Max. altitude above sea level	3300 ft. (1000 m)



VLT® MICRO

Specifications

AC Line 1Ø and 3Ø, 200 - 240 Volt

VLT Order Number	1Ø/3Ø	176F7300	176F7301	176F7302	176F7330	
	1Ø/3Ø	176F7306	176F7307	176F7308	---	
	3Ø	---	---	---	---	176F7331
Output current						
continuous	(200-240) [A]	2.5	5.0	7.0	10	17
intermittent	(200-240) [A]	3.7	7.5	10.5	15	25.5
Output	(200-240) [KVA]	1.0	1.9	2.7	3.8	6.5
Typical shaft output	[HP]	0.5	1.0	2.0	3.0	5.0
	[kW]	0.4	0.75	1.5	2.2	3.7
Max. motor cable size	[AWG]	12	12	12	8	8
	[mm ²]	3.3	3.3	3.3	8.4	8.4
Torque Rating	[kgf-cm]	14	14	14	15	15
Max. input current	1Ø, 200-240 [A]	6.3	11.5	15.7	27	---
	3Ø, 200-240 [A]	3.2	6.3	9.0	15	19.6
Max. power cable size	[AWG]	12	12	12	8	8
	[mm ²]	3.3	3.3	3.3	8.4	8.4
Max. pre-fuses ¹⁾	1Ø [A]	10	20	25	60	---
	3Ø [A]	10	20	25	40	60
Enclosure		Chassis (IP20)				
Weight	1Ø [lbs.]	3.75	4.0	4.25	9.25	9.0

¹⁾ 200-240 VAC; Bussmann type JJJN or exact equivalent

Specifications

AC Line 3Ø, 380 - 480 Volt

	3Ø	176F7312	176F7313	176F7314	176F7332
Output current					
continuous	(380-480) [A]	3.0	4.0	5.0	8.2
Output	(380-480) [KVA]	2.3	3.1	3.8	6.2
Typical shaft output	[HP]	1.0	2.0	3.0	5.0
	[kW]	0.75	1.5	2.2	3.7
Max. motor cable size	[AWG]	12	12	12	8
	[mm ²]	3.3	3.3	3.3	8.4
Max. input current	(380-480) [A]	4.2	5.7	6.0	8.5
Max. power cable size	[AWG]	12	12	12	8
	[mm ²]	3.3	3.3	3.3	8.4
Torque Rating	[kgf-cm]	14	14	14	15
Max. pre-fuses ¹⁾	[A]	10	15	20	30
Enclosure		Chassis (IP20)			
Weight	[lbs.]	2.25	2.5	2.75	9.0

¹⁾ 380-480 VAC; Bussmann type JJS or exact equivalent

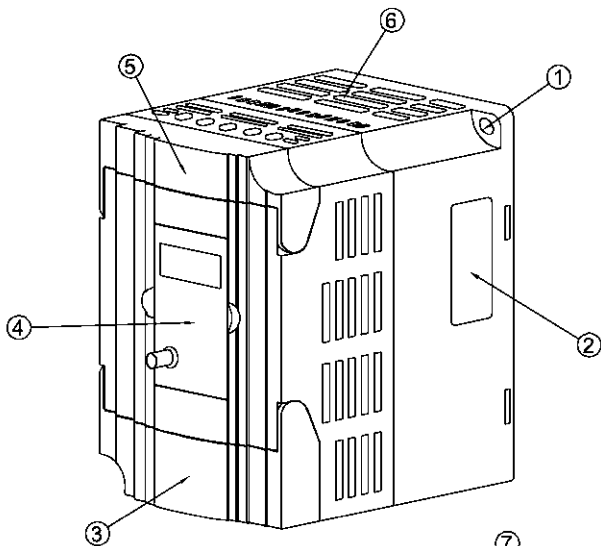

- ① :Mounting Screw Holes
- ② :Nameplate Label
- ③ :Bottom Cover
- ④ :Digital Keypad
- ⑤ :Upper Cover
- ⑥ :Ventilation Hole
- ⑦ :Input Terminals
- ⑧ :Control Input/Output Terminals
- ⑨ :External Braking Resistor
- ⑩ :Output Terminals
- ⑪ :Earth Connection

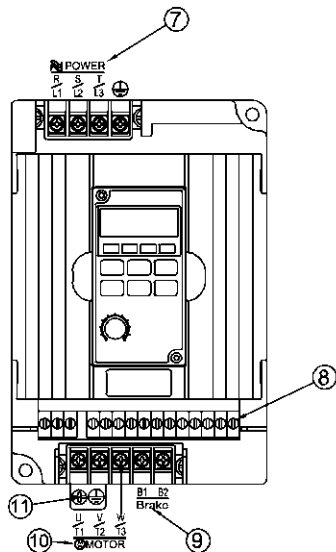

Chapter 2**Installation and Wiring**

Chapter 2 provides the information needed to properly install and wire the AC motor drive. Make sure that the AC drive is wired according to the instructions contained in this chapter. The instructions should be read and understood before the actual installation begins. This chapter contains the following information:

- Installation Requirements
- Wiring

Installation Requirements

Install the drive vertically to provide proper ventilation. Adequate space is required between the drive and a wall or other equipment. The figure below shows the minimum space needed.

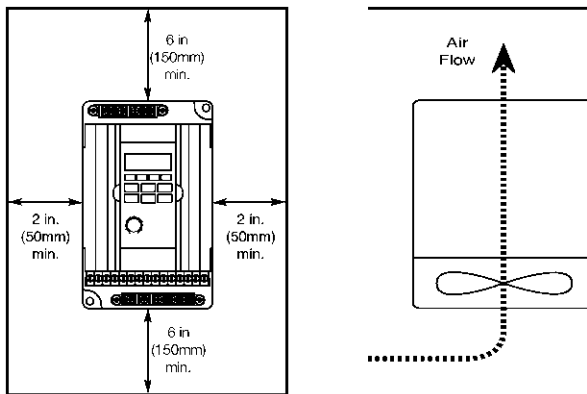
**The AC motor drive should be installed in an environment that is:**

- protected from rain or moisture
- protected from direct sunlight
- protected from corrosive gases or liquids
- free from airborne dust or metallic particles
- free from vibration
- free from magnetic noise
- Climate condition : Class 3K3 (temperature between -10°C to 50°C , Operation above 40°C requires good ventilation to avoid over-heating.)

Wiring

There are two wiring systems in an AFD: Main Circuit and Control Circuit. The Main Circuit terminals are located at the top of the drive. Control Circuit terminals are located bottom of drive. Both terminal blocks are covered by the plastic housing. Lift the hinged portion of the housing to gain access to the terminals. Make sure power is removed before making any connections. Connect wires to the terminals according to the diagram below. When no connections are made to the control terminals, the drive is operated by the Digital Keypad/Display.

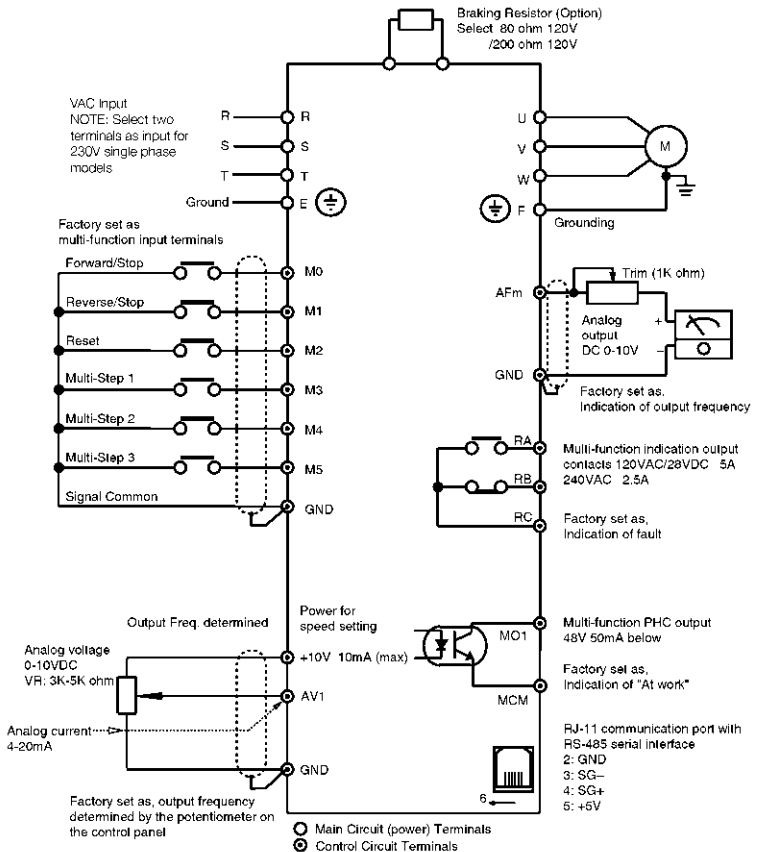

* NOTE: Do not plug a modem or telephone in to the RS485 port. Do not use terminals 2 or 5 when using the port.

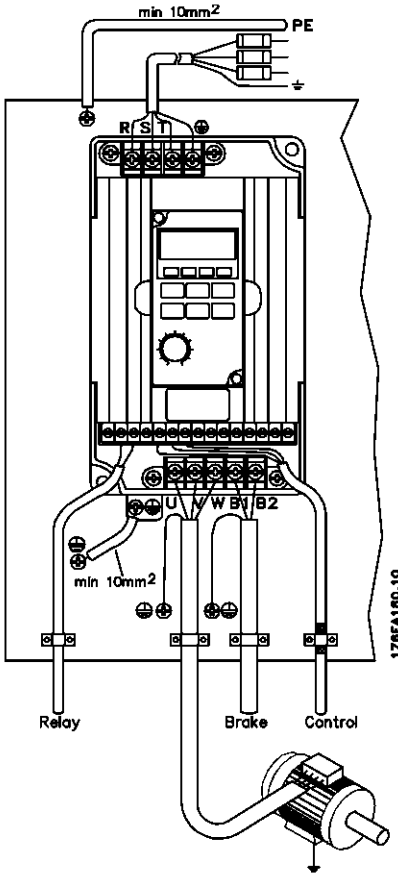
Installation without RFI-filter

200-240 VAC units

Recommended Input Fuses
BUSSMAN Type JJN

Fuse

- VLT MICRO model 176F7300 JJN-10
- VLT MICRO model 176F7301 JJN-20
- VLT MICRO model 176F7302 JJN-25
- VLT MICRO model 176F7306 JJN-10
- VLT MICRO model 176F7307 JJN-20
- VLT MICRO model 176F7308 JJN-25

380-480 VAC units

Recommended Input Fuses
BUSSMAN Type JJS

Fuse

- VLT MICRO model 176F7312 JJS-10
- VLT MICRO model 176F7313 JJS-15
- VLT MICRO model 176F7314 JJS-20

NOTE:

1. Main-circuit terminals spec. is M3.
2. Main-circuit wiring is 600V 14AWG max.
3. Unscreened wiring between drive and motor should not exceed 330 ft. (100m).
 - (1) 100 ft. (30m) below, the PWM carrier frequency should be 15kHz below.
 - (2) 165 ft. (50m) below, the PWM carrier frequency should be 10kHz below.
 - (3) 300 ft. (100m) below, the PWM carrier frequency should be 5kHz below.
4. Voltage drop (V) = $\sqrt{3} \cdot \text{line resistance} (\Omega \cdot \text{Km}) \cdot \text{line length (m)} \cdot \text{Current (A)} \cdot 10^{-3}$
5. Screened wiring between drive and motor should not exceed 50 ft. (15m).

Connection for optional brake resistor.
Refer to Appendix for model numbers.

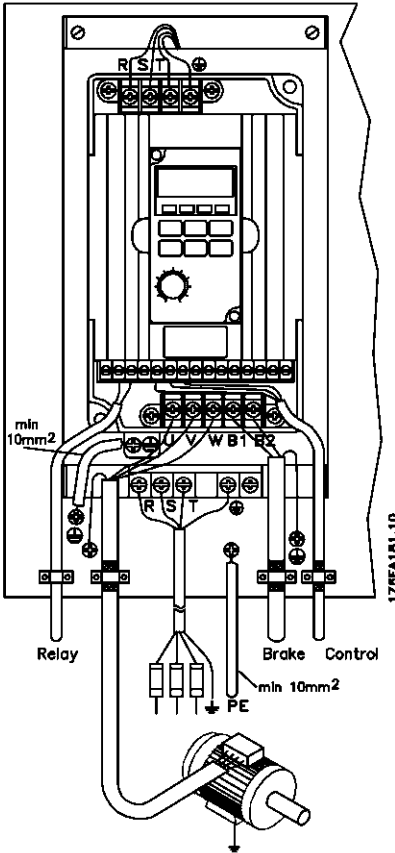
EMC correct installation with RFI-filter

General points to be observed to ensure EMC-correct electrical installation.

- Use only screened/armoured motor cables and screened/armoured control cables.
- Connect the screen to earth at both ends.
- Avoid installation with twisted screen ends (pig-tails), since this ruins the screening effect at high frequencies. Use cable clamps instead, from the installation plate through the installation screws to the metal cabinet of the AC drive.
- Use starwashers and galvanically conductive installation plates.
- Do not use unscreened/unarmoured motor cables in the installation cabinets.

The illustration below shows EMC-correct electrical installation, in which the AC drive has been installed.

Use of EMC compliant cables

In order to comply with requirements for EMC immunity of the control cables and EMC emissions from the motor cables screened/ armoured cables must be used.

The ability of a cable to reduce the amount of ingo-ing and outgoing radiation of electric noise depends on the transfer impedance (Z_T). The screen of a ca-ble is normally designed to reduce the transfer of electric noise, and a screen with a lower Z_T is more effective than a screen with a higher Z_T .

Z_T is rarely stated by cable manufacturers, but it is often possible to estimate Z_T by looking at and assessing the physical design of the cable. Z_T can be assessed on the basis of the following factors:

- the contact resistance between the individual screen conductors.
- Screen coverage, i.e. the physical area of the cable covered by the screen. Is often stated as a percentage and should be no less than 85%.
- The screen type, i.e. braided or twisted pattern. A braided pattern or closed pipe is recommended.

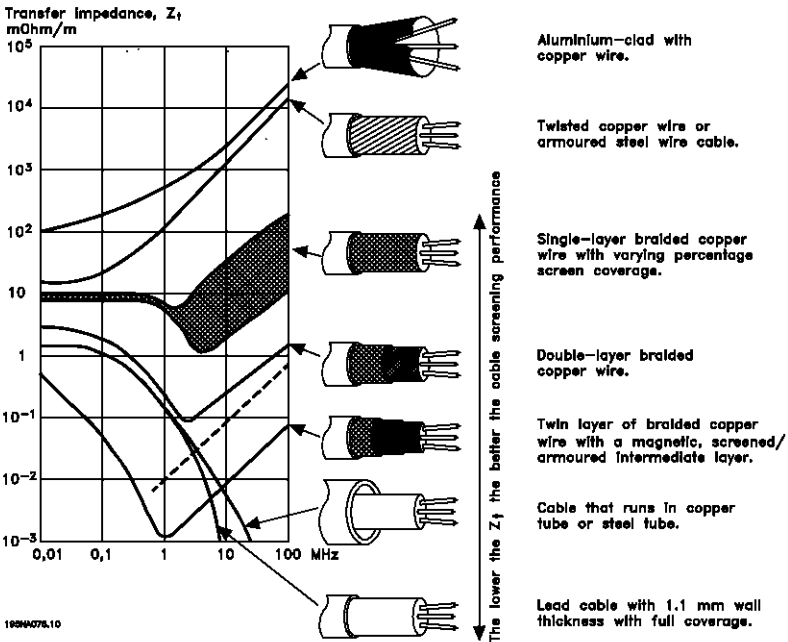

Earthing of screened/armoured control cables

In general control cables must be screened/armoured, and the screen must be connected to the unit's metal cabinet with a cable clamp at each end. The drawing below shows the correct way to perform the earthing, and what to do when in doubt.

1. Correct earthing

Control cables and cables for serial communication must be attached with cable clamps at both ends to ensure maximum possible electrical contact.

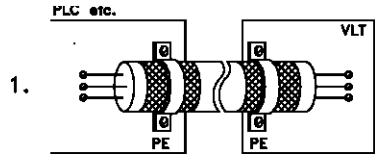
2. Incorrect earthing

Do not use twisted screen ends that are plaited together (pigtailed), as these increase screen impedance at higher frequencies.

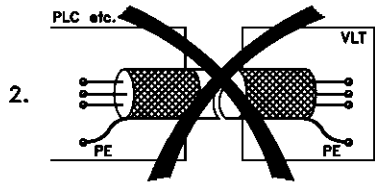
3. Protection with respect to earth potential between PLC and VLT

If the earth potential between the VLT adjustable frequency drive and the PLC (etc.) is different, electric noise may occur that will disturb the whole system. This problem can be solved by fitting an equalising cable, to be placed next to the control cable. Minimum cable cross-section: 16 mm².

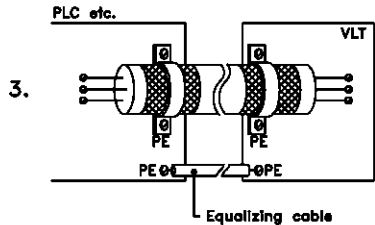
4. In the event of a 50/60 Hz earth loop

If very long control cables are used, 50/60 Hz earth loops can arise, and these can interfere with the whole system. This problem is resolved by attaching one end of the screen to the earth via a 100 nF capacitor (short pin length).

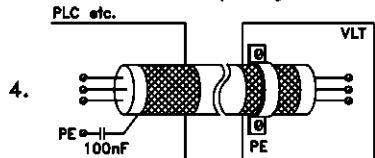

185NA100.12

Control Terminal Designations

AWG 12-14

Torque 4 kg-cm

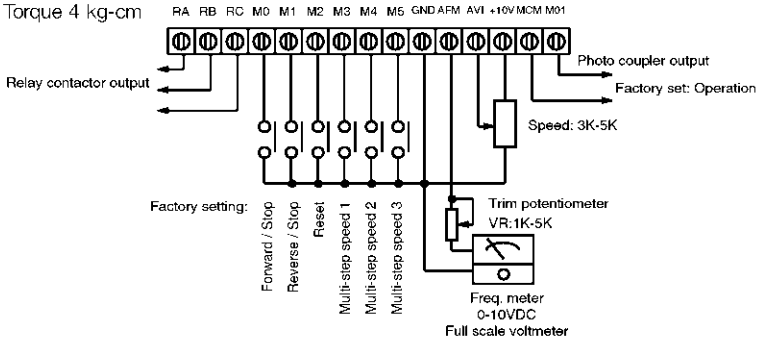

Terminal symbol	Terminal name	Remarks
RA - RC	Multi-function output contact	Refer to P46,
RB - RC	Multi-function output contact	Relay Output Contact
M0 - GND	Multi-function input 1	Refer to P38, 39, 40, 41, 42
M1 - GND	Multi-function input 2	
M2 - GND	Multi-function input 3	
M3 - GND	Multi-function input 4	
M4 - GND	Multi-function input 5	
M5 - GND	Multi-function input 6	
M01 - MCM	Multi-function PHC output 1	Refer to P45
+10V - GND	Power supply for speed control	Command for power supply (+10 V)
AVI - GND	Analog voltage freq. command	0 - 10V or 4 - 20mA inputs (10V and 20mA = max. freq.)
AFM - GND	Analog frequency/current meter	0 - 10 V output (10 V = max. freq.)

Note : Use twisted-shielded or twisted-pair shielded wires for the control signals. It is recommended to run all signal wiring in a separate steel conduit. The shielding should be connected at both ends .

Installation Notes:

- Make sure that the appropriate input fusing with specified current ratings are connected between the AC Power Line and the AC drive. A MCC (contactor with magnetic trip) is recommended between the drive and circuit breaker to provide a means to disconnect the drive from the power line in the event of a fault.
- Make sure that the leads are connected correctly and the drive is properly grounded. (Ground leads should be at least as the same size as input terminals R, S and T.)
- Use ground leads that comply with AWG standards. Make the length of these ground leads as short as possible.
- Should several units be installed side by side, all the units should be grounded directly to the ground terminal. Do not form a loop with the ground leads.

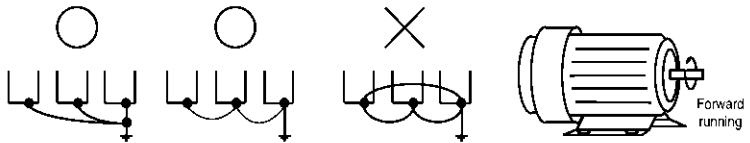

- When the drive output terminals U, V, and W are connected to the motor terminals U, V, and W, respectively, the motor will rotate counter-clockwise (viewed from the shaft of the motor as shown above) when a forward operation command is received (FWD lamp is ON).
- Make sure that the power source supplies the correct voltage and is capable of supplying the required current to the drive.
- When power is applied to the drive, the internal DC bus charge indicator LED will be on.
- Do not attach or remove wiring or connectors when power is applied to the drive. Do not attempt to probe signals on the circuit board while the drive is operating.
- For single phase applications, the AC input line can be connected to any two of the three input terminals R, S, T. Note: The drive is not intended for use with single-phase motors.
- To reverse the direction of rotation, interchange the connection of any of the two motor leads.
- Do not connect the AC input to any of the U, V, W terminals, as this will damage the drive.

- Avoid loose wiring and possible shorts. Tighten all screws on AC circuit terminals securely.
- It is a good practice to maintain a 90° angle between wires connected to the AC circuit terminals and wires connected to the control terminals.
- Use shielded cables for Control Circuit wiring,
- Use conduit for the AC power line. The conduit on both the input and output of the power line should be grounded.
- If an EMI filter is required, it should be located close to the drive. Reducing carrier frequency can also be a way to reduce EMI noise, however audible noise from the motor will increase.
- An L-Filter can be added to the U.V.W. side of AC Motor Drives if needed. Do not use a Capacitor, or L-C Filter (Inductance-Capacitance), or R-C Filter (Resistance-Capacitance).
- A "Ground Fault Interrupt Circuit" can be used. To avoid malfunctioning of the motor and drive, sensitivity of the current sensor should not be less than 200 mA with a response time not less than 0.1 second.

Chapter 3

Digital Keypad/Display Operation

Chapter 3 describes the various controls and indicators found on the Digital Keypad/Display. The information in this chapter should be read and understood before performing the start-up procedures described in Chapter 4.

- Description of the Digital Keypad/Display
- Description of Display
- Digital Keypad Operating Modes & Programming Steps

Description of the Digital Keypad/Display Operating Modes and Functions

When delivered from the factory, the Digital Keypad/Display module is mounted on the front panel of the AC drive. This module has two functions: display and control. The Display shows the current status of the drive. The control function provides the programming interface.

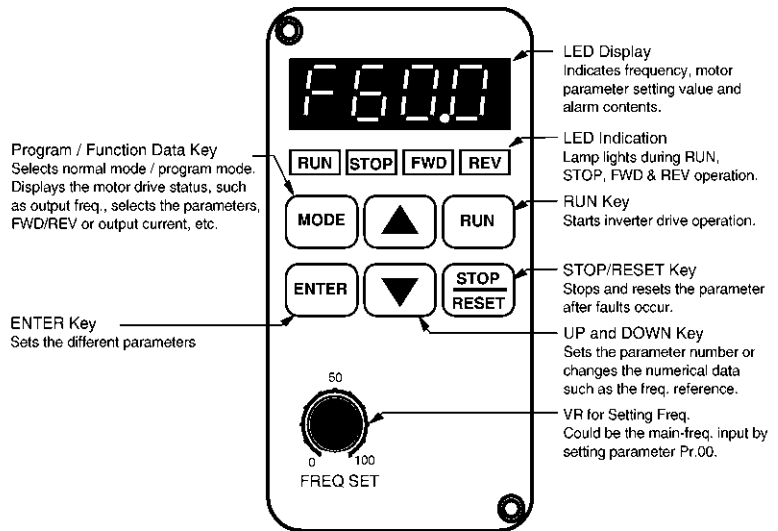

MODE

Function / Program

Pressing the "mode" key repetitively displays the AFD status such as the reference frequency, output frequency, direction or output current and selects the parameter setting mode.

ENTER

Enter

Pressing the "ENTER" key to enter the data change mode and again to store the value in memory.

RUN

Run

Used to start the AC drive operation. This key has no effect when the drive is controlled by the External Control Terminals.

**STOP
RESET**

Stop / Reset

Used to stop AC drive operation. If the drive has stopped due to a fault, clear the fault first, then press this key to reset the drive. This key has no effect when the drive is controlled exclusively by the External Control Terminals.

▲

Up / Down

Press the "Up" or "Down" keys momentarily to change parameter settings. These keys may also be used to scroll through different operating values or parameters. Pressing the "Up" or "Down" key momentarily, will changes the parameter settings in single-unit increments. To quickly run through the range of settings, press down and hold the key.

▼

Press the "Up" or "Down" key momentarily to select Forward or Reverse directions when in Direction Mode and the drive is controlled by the digital control panel.

Explanation of the LED Indicators

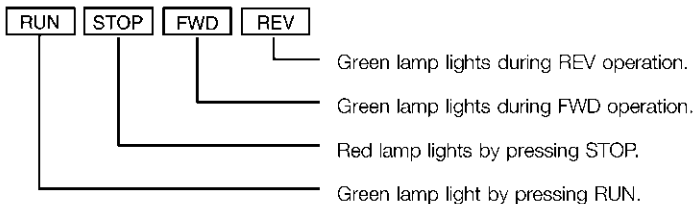

Quick Set-up

Refer to the relevant chapters of this manual for detailed instructions to configure the VLT MICRO for your specific requirements.



Before you start, please read the safety instructions in Chapter 1 of this manual. The adjustable frequency drive contains dangerous voltages when connected to the AC line. Improper connection of the motor or the VLT MICRO may cause equipment failure, serious injury or death. Follow the directions in this Quick Set-up, as well as all local and national safety codes.

Electrical Installation, Power

Connect the AC line and motor cables as shown in Chapter 2 of this manual.

Programming

The VLT adjustable frequency drive is programmed by means of the Digital Keypad. Refer to Chapter 3 for the keypad functions.

In order to operate in Quick set-up the Pin Header/Jumpers (located next to the input terminals) should be as shown.

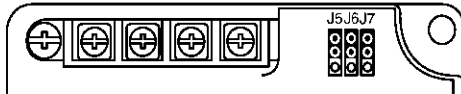
NOTE:

Speed reference is controlled by the "Arrow" keys. If the potentiometer is to be used as the speed reference parameter Pr.00 will need to be programmed to d01.

Set the following parameters according to the motor nameplate:

Max motor frequency Parameter Pr.04
 Max motor voltage Parameter Pr.05
 Motor rated current Parameter Pr.52

$$\text{Pr.52} = \frac{\text{Motor Full Load Amps}}{\text{Drive's Max. Cont. Amps}} \times 100$$

Set the ramp times:

Accel time Parameter Pr.10
 Decel time Parameter Pr.11

Motor Start

Press the "RUN" key to start the motor. Adjust desired speed using the "Arrow" keys.

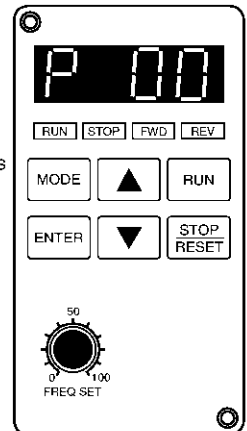

Drive's Max Continuous Amps	
Model: 240V	Amps
176F7300	2.5
176F7301	5.0
176F7302	7.0

Drive's Max Continuous Amps	
Model: 460V	Amps
176F7312	3.0
176F7313	4.0
176F7314	5.0

Explanation of Displayed Messages
F600

Displays the AC drives output frequency. The frequency may be determined by any one of the frequency sources that is selected by the [Master frequency setting] or [Jog Frequency] command. It may also be set using the [Multi-step speed setting 1 - 7] as determined by the inputs to Multi-function Input terminals 1, 2 and 3.
If the frequency source originates from the control panel, the user can use either the "up" or "down" key to select the frequency.

H600

Displays the output frequency present at terminals U, V, and W.
Displays the custom unit (v), where $v = H \times \text{Pr.-65}$.
Displays the internal counter value (C).
Note : Refer to Chapter 5, Pr.-45, 46, 64 - 66 for detailed description.

v600

Displays the custom unit (v), where $v = H \times \text{Pr.-65}$.

r180

Displays the custom unit (r), where $r = H \times \text{Pr.-65}$.

L500

Displays the custom unit (L), where $L = H \times \text{Pr.-65}$.

%366

Displays the custom unit (%), where $\% = H \times \text{Pr.-65}$.

c999

Displays the counter value (c).

A 50

Displays the output current present at terminals U, V, and W

I 50

Displays the internal PLC process step currently being performed.

P 01

Displays the specified parameter.

d 01

Displays the actual value stored within the specified parameter.

Frd

AC drive forward run status.

rEv

AC drive reverse run status.

End

The display will read "end" (as shown in the display to the left) for approximately 1 second if an input has been accepted. After a parameter value has been set, the new value is automatically stored in memory. To modify an entry, use the "up" and "down" keys.

Err

The display will read "Err", if as input is not accepted, or a parameter value is selected outside the limit of the parameter.

- Operating the Digital Control Panel
- Indicate the operation mode.

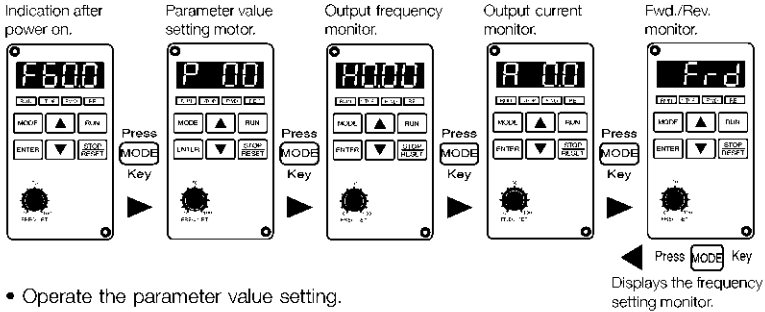

- Operate the parameter value setting.

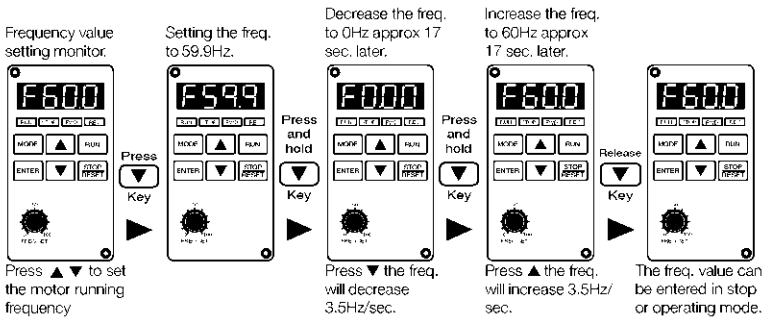
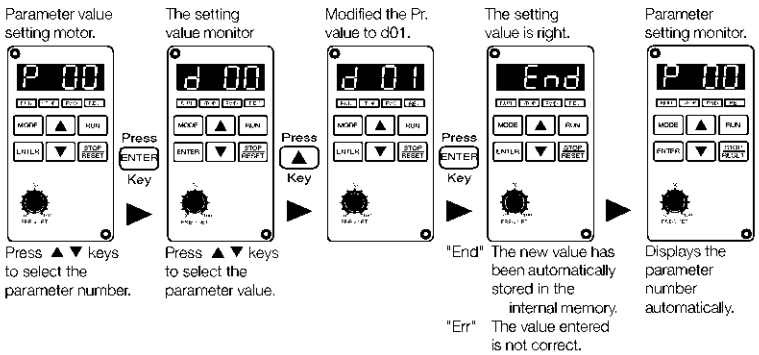

Note: Set parameter Pr.00 to d00 to enable setting the frequency by the keypad.

- Change the different indication mode as follows:

Indication after power on.

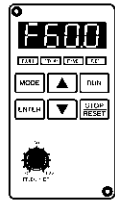

"STOP" "FWD" will light up.

Operate at 60.0Hz.



"RUN" "FWD" will light up.

Output frequency monitor.



After 10 sec.
Press
MODE
Key
twice

Output current monitor.

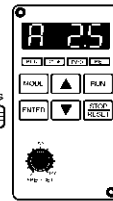

Press
MODE
Key

Forward operation monitor.

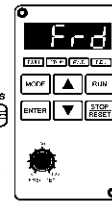

Press
MODE
Key

Change the Fwd. or Rev. operation.

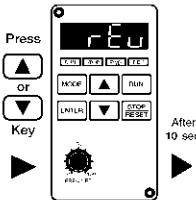

"RUN" "REV" will light
"FWD" will flash.

Change to Reverse operation.

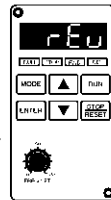

After 10 sec.

Setting the frequency.

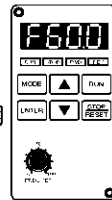

Press
MODE
Key

Decrease motor speed to stop.



Press
STOP
RESE
Key

"STOP" "REV" will
light "RUN" will
flash.

Stop mode.



"STOP" "REV"
will light up.

- Reset the fault messages.

Fault message
O.H. is displayed.



Press
STOP
RESE
Key

Frequency setting
will be displayed
after the fault is
removed.

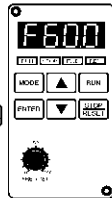

Chapter 4
Description of Parameters
Pr.00 Master Frequency Source Select

Factory Setting d00

Units None

Settings d00 Master frequency determined by keypad digital control.

 d01 Master frequency determined by analog signal of DC 0V - +10V,
 a. Performed by keypad potentiometer. The pin header and jumper
 combined as ① and ③ in the diagram below.

 b. Performed by external terminal AV1. The pin header and jumper
 combined as ② and ③ in the diagram below.

 d02 Master frequency determined by analog signal of DC 4mA - 20mA.
 Performed by external terminal AV1. The pin header and jumper
 combined as ② and ④ in the diagram below.

Pin Header/Jumper Diagrams:

The pin headers and jumpers are located on the upper right corner of the control board and can be accessed by opening the input terminal cover.

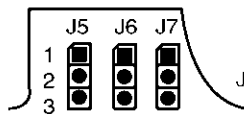

J5: Selects the source of the potentiometer input from the External Control Terminal (AV1) or from the Digital Keypad/Display (LC-03P) potentiometer.

J6, J7: This jumper is used to select the DC voltage signal or DC current signal for master frequency control.

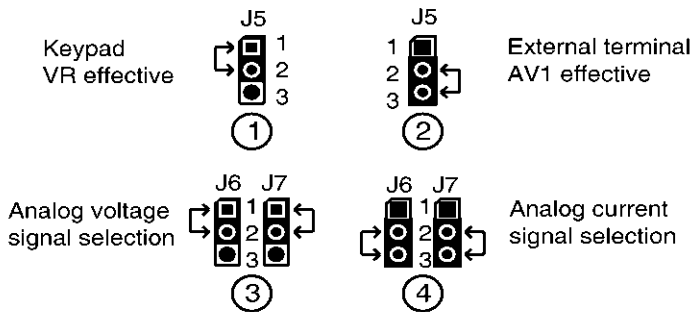

Pr.01 Operation Command Source Select

Factory Setting d00
Units None

Settings d00 Operating instructions determined by the Digital Keypad/Display.

d01 Operating instructions determined by the External Control Terminals.

Keypad STOP key is effective.

d02 Operating instructions determined by the External Control Terminals.

Keypad STOP key is not effective.

(Refer to parameters 38, 39, 40, 41 and 42 for more details.)

Pr.02 Motor Stop Method Select

Factory Setting d00
Units None

Settings d00 Ramp stop

d01 Coast to stop

This parameter determines how the motor is stopped when the AC drive receives a valid stop command.

Ramp: The AC drive output frequency decelerates down to the minimum output frequency (Pr.08) in the time specified by Pr.11 or Pr.13, then the output is turned off.

Coast: The AC drive output is turned off immediately and the motor free runs until it comes to a stop.

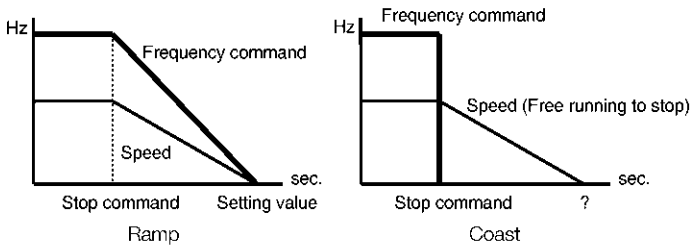

To determine the best method to stop the motor, the type of load needs to be considered.

1. In many applications operator safety and material processing can be improved when "Ramp Stop" is selected. The accel./decel. time required will depend on the specific parameters of your application.
2. The advantage of using "Coast-to-stop" is the motor will heat less during frequent starting and stopping. Applications where "Coast-to-stop" is commonly used are fans, pumps, blowers, mixing and agitating.

Pr.03, Pr.04, Pr.05, Pr.06, Pr.07, Pr.08, Pr.09 V / F Curve**Pr.03 Maximum Output Frequency**

Factory Setting d60.0 Hz
Units 0.1 Hz
Parameter value d50.0 - d400.0 Hz

This parameter determines the maximum AC drive output frequency. Analog inputs (0 - 10 V, 4 - 20 mA) are scaled to correspond to the output frequency range.

Pr.04 Motor Frequency

Factory Setting d60.0 Hz
Units 0.1 Hz
Parameter value d10.0 - d400.0 Hz

This value should be set according to rated frequency of the motor as indicated on the motor nameplate.

Pr.05 Motor Voltage

<u>240V</u>	<u>460V</u>
Factory Setting d220.0	Factory Setting d440.0
Units 0.1 V	Units 0.2 V
Parameter value d2.0 - d255.0	Parameter value d4.0-d500.0

This parameter determines the Maximum Output Voltage of the AC drive. The maximum output voltage setting must be smaller than or equal to the rated voltage of the motor as indicated on the motor nameplate.

Pr.06 Mid-point Frequency

Factory Setting d1.50 Hz
Units 0.1 Hz
Parameter value d0.1 - d400.0 Hz

This parameter sets the Midpoint Frequency of the V/F curve. It may be used to determine the V/F ratio between the Minimum Frequency and the Mid-point Frequency.

Pr.07 Mid-point Voltage

<u>240V</u>	<u>460V</u>
Factory Setting d10.0 V	Factory Setting d20.0 V
Units 0.1 V	Units 0.2 V
Parameter value d2.0 - d255.0	Parameter value d4.0 - d500.0

This parameter sets the Midpoint Voltage of the V/F curve. It may be used to determine the V/F ratio between the Minimum Voltage and the Mid-point Voltage.

This parameter must be equal to or greater than Minimum Output Voltage (Pr.09) and equal to or less than Maximum Output voltage (Pr.05)

Pr.08 Minimum Output Frequency

Factory Setting d1.50 Hz
 Units 0.1 Hz
 Parameter value d0.1 - d20.0 Hz

This parameter programs the Minimum Output Frequency of the AC drive.

Pr.09 Minimum Output Voltage

240V
 Factory Setting d10.0 V
 Units 0.1 V
 Parameter value d2.0 - d50.0 V

460V
 Factory Setting d20.0 V
 Parameter value d2.0 to d100

This parameter programs the Minimum Output Voltage of the AC drive.
 This parameter must be equal to or less than Mid-Point Voltage (Pr.07).

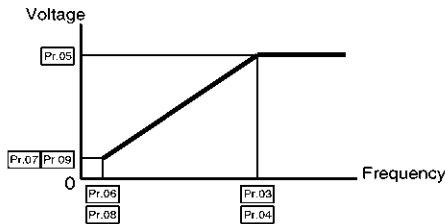

Standard V/F Curve

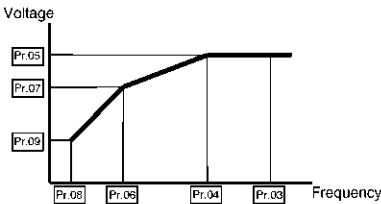

Custom V/F Curve

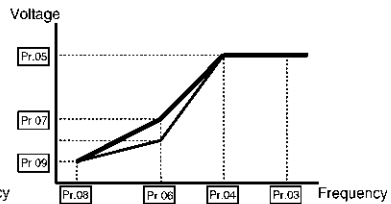

Fan/Pump V/F Curve

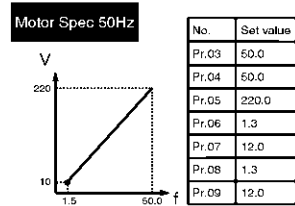
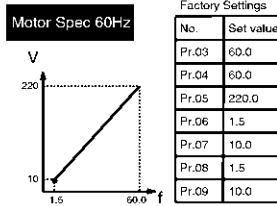
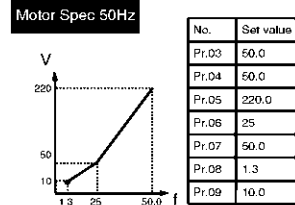
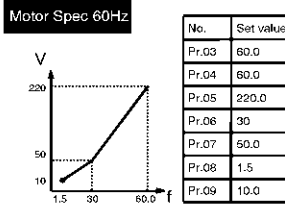
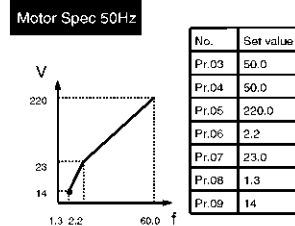
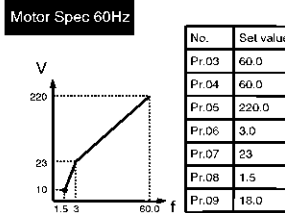
Commonly Used V/F Pattern Settings
(1) General Purpose

(2) Fans and Pumps

(3) High Starting Torque

Pr.10, Pr.11, Pr.12, Pr.13 Acceleration / Deceleration Time
Pr.10 Acceleration Time 1 (Can be programmed while the drive is running.)

Factory Setting d10.0 Sec

Units 0.1 Sec

Parameter value d0.1 - d600.0 Sec

This parameter is used to determine the time required for the AC drive to ramp from 0 Hz to its Maximum Output Frequency (Pr.03). The rate is linear unless S Curve is "enabled". This rate of acceleration applies to any incremental increase in command frequency unless selected using the Multi-Function Inputs, M11 - 3. See Parameters 39, 40 and 41. Acceleration time 1 is the default when a Multi-Function Input Terminal has not been programmed to select between Acceleration time 1 and Acceleration time 2.

Pr.11 Deceleration Time 1 (Can be programmed while the drive is running.)

Factory Setting d10.0 Sec

Units 0.1 Sec

Parameter value d0.1 - d600.0 Sec

This parameter is used to determine the time required for the AC drive to decelerate from the Maximum Output Frequency (Pr.03) down to 0 Hz. The rate is linear unless S Curve is "enabled". Deceleration time 1 is the default when a Multi-Function Input Terminal has not been programmed to select between Deceleration time 1 and Deceleration time 2.

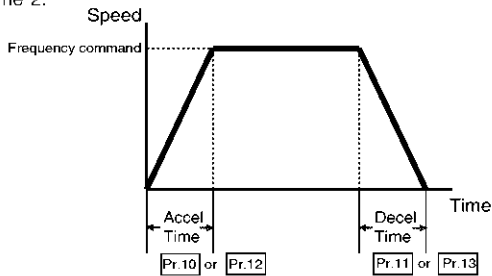

Note: See Pr.101; Automatic Accel and Decel times are default. Change to "Linear Acceleration/Deceleration" to enable manual adjustment.

Pr.12 Acceleration Time 2 (Can be programmed while the drive is running.)

Factory Setting d10.0 Sec

Units 0.1 Sec

Parameter value d0.1 - d600.0 Sec

This parameter determines the time required for the AC drive to ramp from 0 Hz to the Maximum Operating Frequency (Pr.03). The rate is linear unless S Curve is "enabled". The rate of acceleration applies to any incremental increase in command frequency unless Acceleration Time 1 (Pr.10) is selected. Acceleration Time 1 and 2 may be selected using the Multi-Function Inputs M1 - 3. (See Parameters 39, 40 and 41.)

Note: See Pr.101; Automatic Accel and Decel times are default. Change to "Linear Acceleration/Deceleration" to enable manual adjustment.

Pr.13 Deceleration Time 2 (Can be programmed while the drive is running.)

Factory Setting d10.0 Sec
 Units 0.1 Sec
 Parameter value d0.1 - d600.0 Sec

This parameter determines the time for the AC drive to decelerate from the Maximum Output Frequency (Pr.03) down to 0 Hz. The rate is linear unless S Curve is "enabled". The rate of deceleration applies to any decrease in command frequency unless Deceleration Time 1 is selected. Deceleration Time 1 and 2 may be selected using the Multi-Function Inputs M1 - 3. (See Parameters 39, 40 and 41.)

Application Notes:

1. The Accel./Decel. Time is defined as the time required to change the output frequency from the value of Pr.03 to the value of Pr.08 (Maximum and Minimum Output Frequencies).
2. The Accel./Decel. time can be calculated by using the parameter values of the following formula: $a = [(Pr.10, 11, 12, 13) / (Pr.03 - Pr.08)] / (Pr.03 - 0 \text{ Hz})$.
3. The actual Accel./Decel. time should be measured to insure it meets the system requirements.

Pr.14 S-curve

Factory Setting d00 Sec
 Units None
 Parameter value d00 - d07

This parameter should be programmed during start-up. It is used to provide smooth acceleration and deceleration. S-curves can be selected from 1 to 7. Settings 1 to 7 are added to the active accel./decel. times to form an adjustable S-curve.

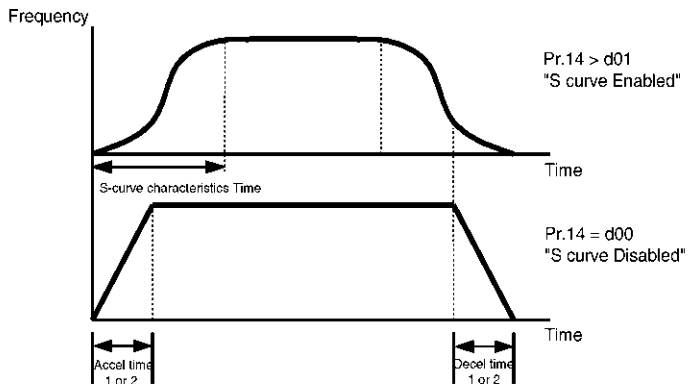

Pr.15 Jog Accel. / Decel. Time (Can be programmed while the drive is running.)

Factory Setting d1.0 Sec

Units 0.1 Sec

Parameter value d0.1 - d600.0 Sec

This parameter, together with the Jog Frequency (Pr.16), determines the time required for the AC drive to ramp from 0 Hz to the Jog Frequency, or the time required to ramp from the Jog Frequency to 0 Hz.

Pr.16 Jog Frequency (Can be programmed while the drive is running.)

Factory Setting d6.00 Hz

Units 0.1 Hz

Parameter value d0.1 - d400.0 Hz

Jog Frequency can be controlled through a Multi-Function Input Terminal: M1 to M5 (See Pr.38 - pr.42). Jog starts from the Minimum Output Frequency (Pr.08) accelerating to the Jog Frequency (Pr.16) in the time interval set by the Accel./Decel. Time (Pr.15).

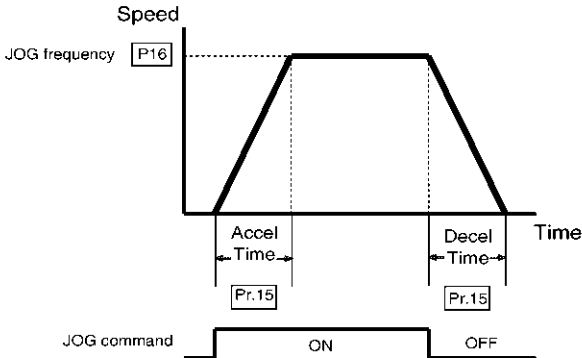

Pr.17, Pr.18, Pr.19, Pr.20, Pr.21, Pr.22, Pr.23 Multi-speed Operation

Multi-Step Speeds 1, 2, 3, 4, 5, 6, 7 (Can be programmed while the drive is running.)

Factory Setting d0.00 Hz

Units 0.1 Hz

Parameter value d0.1 - d400.0 Hz

Multi-step speed Parameters 17 - 23 in conjunction with Parameters 78, 79, 81 - 87 provide multi-step motion control.

Pr.24 Reverse Run Inhibit

Factory Setting d00
Units None
Settings d00 REV run enabled
d01 REV run disabled

This parameter inhibits AC drive operation in the reverse direction.

Pr.25 Over-voltage Stall Prevention

Factory Setting d01
Units None
Settings d00 Disable over-voltage stall prevention
d01 Enable over-voltage stall prevention

During deceleration, the DC bus voltage may exceed the maximum amount allowable due to motor regeneration. When this function is enabled, the AC drive will cease to decelerate and then maintain a constant output frequency. The drive will only resume deceleration when the voltage drops below the preset value.

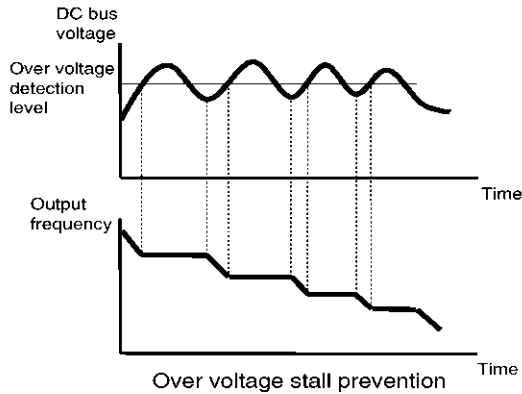
**Pr.26, Pr.27 Over-Current Stall Prevention****Pr.26 Over-Current Stall Prevention During Acceleration**

Factory Setting d170%
Units 1%
Parameter value d50 - d200%

During periods of rapid acceleration or excessive load, the AC drive output current may increase abruptly and exceed the value specified by Pr.26. When this function is enabled, the AC drive will cease to accelerate, then maintain a constant output frequency. The drive will only resume acceleration when the current drops below the preset value.

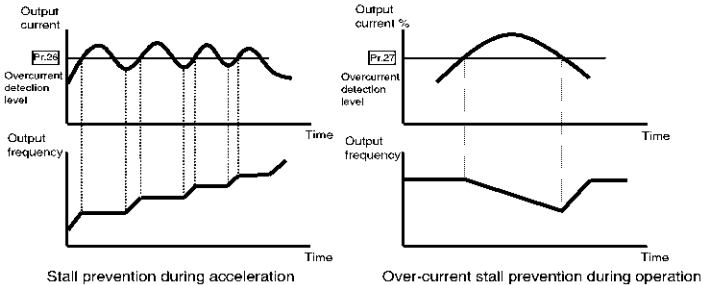

Pr.27 Over-Current Stall Prevention During Operation

Factory Setting d170%
 Units 1%
 Parameter value d50 - d200%

During steady-state operation with the motor load rapidly increasing, the AC drive output current may exceed the limit specified in Pr.27. When this occurs, the output frequency will decrease to maintain a constant motor speed. The drive will accelerate to the steady-state operating frequency only when the output current drops below the level specified by Pr.27. A setting of 100% is equal to the rated current of the drive.

Pr.28, Pr.29, Pr.30, Pr.31 DC Braking Current

Pr.28 DC Braking Current

Factory Setting d00%
 Units 1%
 Parameter value d00 - d100%

This parameter determines the DC current that will be applied to the motor during braking when the Motor Stop Method (Pr.02) is programmed to "Ramp Stop". The DC braking current is set at increments of 1%. A setting of 100% is equal to the rated current of the drive.

NOTE: When setting this parameter, begin at a lower current level, then increase the value until sufficient holding torque is achieved. The rated motor current should not be exceeded.

Pr.29 DC Braking Time During Start-up

Factory Setting d0.0 Sec
 Units 0.1 Sec
 Parameter value d0.0 - d5.0 Sec

This parameter determines the time duration that DC braking current will be applied to the motor during the AC drive start-up.

Pr.30 DC Braking Time During Stopping

Factory Setting d0.0 Sec
 Units 0.1 Sec
 Parameter value d0.0 - d25.0 Sec

This parameter determines the time duration that DC braking current will be applied to the motor when the Motor Stop Method (Pr.02) is set to "Ramp Stop".

Pr.31 DC Braking Start-up Frequency

Factory Setting d0.00 Hz
 Units 0.1 Hz
 Parameter value d0.0 - d60.0 Hz

This parameter determines the Start-up Frequency for DC braking when the AC drive starts to decelerate. The frequency may be set in 0.1 Hz increments. When the value is less than that specified by Pr.08, Minimum Output Frequency, the start-up frequency for DC braking will be the value specified by this parameter.

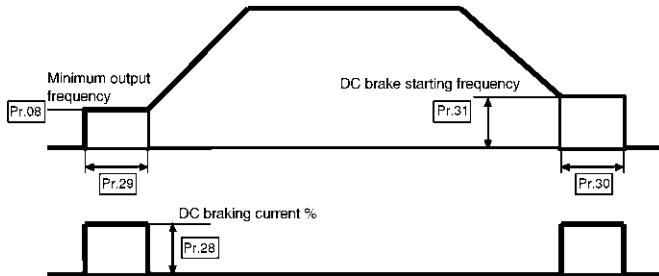
Pr.32, Pr.33, Pr.34, Pr.35 Momentary Power Loss Protection
Pr.32 Momentary Power Loss Operation Mode Selection

Factory Setting d00
 Units None

Settings d00 Operation stops after momentary power loss.
 d01 Operation continues after momentary power loss. Speed search starts with the Frequency Reference Value.

d02 Operation continues after momentary power loss. Speed search starts with the Minimum Frequency.

NOTE: Fault contact is not energized during restart after a momentary power loss. This parameter determines the AC drive mode of operation after recovery from a momentary power loss.

Pr.33 Maximum Allowable Power Loss Time

Factory Setting d2.0 Sec
 Units 0.1 Sec
 Parameter value d0.3 - d5.0 Sec

During a power failure, if the power loss time is less than the time defined by this parameter, the AC drive will resume operation. If the Maximum Allowable Power Loss Time is exceeded, the AC drive output power will be turned off.

Pr.34 Minimum Base Block Time

Factory Setting d0.5 Sec
 Units 0.1 Sec
 Parameter value d0.3 - d5.0 Sec

When a momentary power loss is detected, the AC drive output turns off for a specified time interval determined by Pr.34 before resuming operation. This time interval is called the "Base Block Time". This parameter should be set to a value where the residual output voltage is nearly zero.

Pr.35 Speed Search Deactivation Current Level

Factory Setting d100%
 Units 1%
 Parameter value d30 - d200%

Following a power failure, the AC drive will start its speed search operation only if the output current is greater than the value determined by Pr.35. When the output current is less than that of Pr.35, the AC drive output frequency is determined to be at a "speed synchronization" point. The drive will start to accelerate or decelerate back to the operating frequency at which it was programmed to operate.

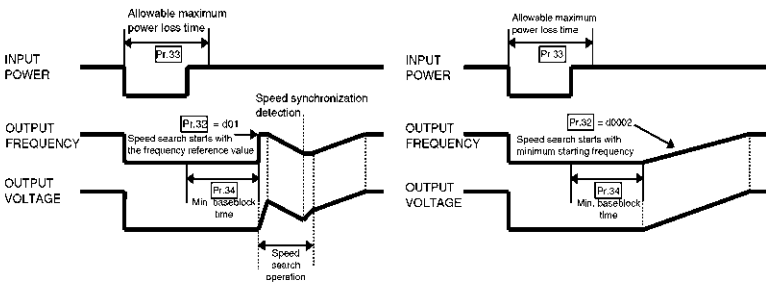

Pr.36, Pr.37 Reference Frequency: Upper / Lower limit**Pr.36 Reference Frequency Upper Limit**

Factory Setting d400.0 Hz

Units 0.1 Hz

Parameter Value d0.1 - d400.0 Hz

This parameter programs the upper limit of the reference frequency in 0.1 Hz increments.

Pr.37 Reference Frequency Lower Limit

Factory Setting d0.0 Hz

Units 0.1 Hz

Parameter Value d0.1 - d400.0 Hz

Determines the lower limit of the reference frequency in 0.1 Hz increments.

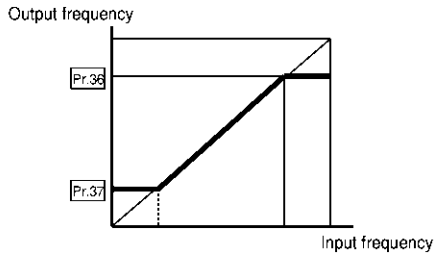
**Application Notes:**

1. Parameters 36, 37 are provided to prevent damage to the AC motor and applicable machinery. Under certain conditions a motor can overheat and/or machinery can be damaged at excessively high speeds.
2. The lower limit for AC drive operation is determined by the greater value of Pr.08 (Minimum Output Frequency) and Pr.37 (Reference Frequency Lower Limit). The upper limit for AC drive operation is determined by the lesser value of Pr.03 (Maximum Output Frequency and Pr.36 Reference Frequency Upper Limit).

Pr.38 Multi-Function Input Terminals (M0, M1)

Factory Setting d00

Units None

Settings d00 - d02

Pr.39 Multi-Function Input Terminals (M2)

Factory Setting d05

Units None

Settings d03 - d20

Pr.40 Multi-Function Input Terminals (M3)

Factory Setting d06
 Units None
 Settings d03 - d20

Pr.41 Multi-Function Input Terminals (M4)

Factory Setting d07
 Units None
 Settings d03 - d20

Pr.42 Multi-Function Input Terminals (M5)

Factory Setting d08
 Units None
 Settings d03 - d20

Parameter - Function List:

Value	Function	Value	Function
d00	M0: Fwd./Stop, M1: Rev./Stop	d11	1st-2nd Accel./Decel. Time Select
d01	M0: Run/Stop, M1: Fwd./Rev.	d12	External Base Block (Normally Closed)
d02	3-Wire Operation Control Mode	d13	External Base Block (Normally Open)
d03	External Fault (Normally Open)	d14	Increase Output Frequency Control
d04	External Fault (Normally Closed)	d15	Decrease Output Frequency Control
d05	External Reset	d16	Run PLC Program
d06	Multi-Step Speed Control 1	d17	Pause PLC Program
d07	Multi-Step Speed Control 2	d18	Counter Trigger
d08	Multi-Step Speed Control 3	d19	Counter Reset
d09	Jog Frequency	d20	No Operation
d10	Accel./Decel. Speed Inhibit Control		

Explanation:

1. **d00, d01: Start/Stop/Directional Control** – Mode 1 - Two wire control: Parameter value set to d00 (Pr.38 only).

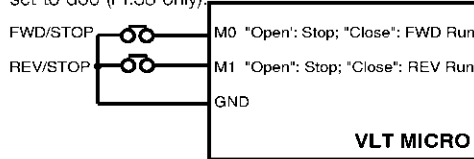

Mode 2 - Two wire control: Parameter value set to d01 (Pr.38 only).

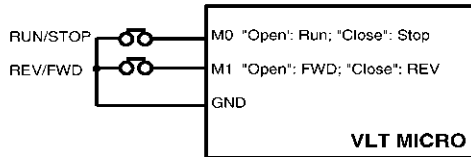

Mode 3 - Three wire control: Parameter value set to d02 (Pr.38 only).

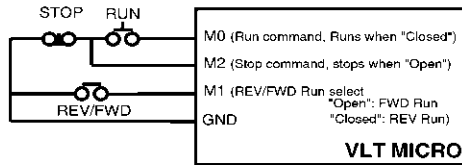

When value d02 is selected for Pr.38, the program value for Pr.39 will be ignored. Three Wire Control remains in effect.

2. **d03, d04: External Fault** – Parameter values d03, d04 programs Multi-Function Input Terminals: M1 (Pr.38), M2 (Pr.39), M3 (Pr.40), M4 (Pr.41) or (Pr.42) to be External Fault (E.F.) inputs.

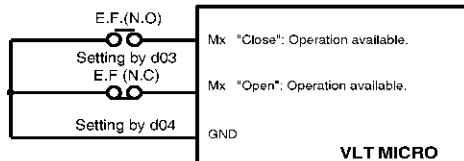

The External Fault input signal has fast priority for display of "E.F." by the Digital Keypad/Display. All AC drive functions will be stopped and the motor will free-run. Normal operation can resume after the external fault is cleared and the AC drive is reset.

3. d05: External Reset – Parameter value d05 programs a Multi-Function Input Terminal: M1 (Pr.38), M2 (Pr.39), M3 (Pr.40), M4 (Pr.41) or M5 (Pr.42) to be External Reset.

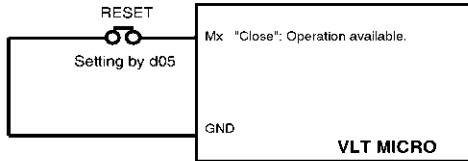

External Reset has the same function as the Reset key on the Digital keypad. External faults O.H., O.C. and O.V. are cleared when this input is used to reset the drive.

4. d06, 07, 08: Multi-Step Speed Command – Parameter values d06, d07, d08 programs any three of the following Multi-Function Input Terminals: M1 (Pr.38), M2 (Pr.39), M3 (Pr.40), M4 (Pr.41) or M5 (Pr.42) for multi-step speed command function.

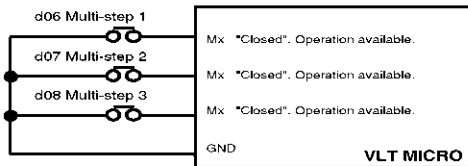

These three inputs select the multi-step speeds defined by Parameters 17 - 23 as shown in the following diagram. Parameters 78 - 87 can also control output speed by programming the AC drive's internal PLC function.

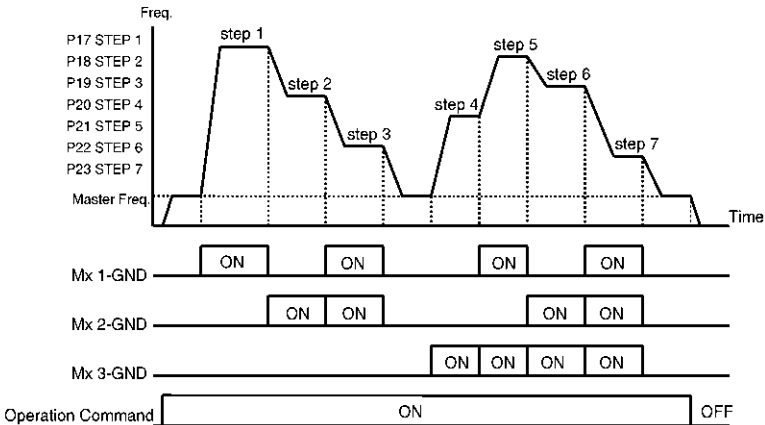

5. d09: Jog Frequency Control – Parameter value d09 programs a Multi-function Input Terminal: M1 (Pr.38), M2 (Pr.39), M3 (Pr.40), M4 (Pr.41) or M5 (Pr.42) for Jog control.

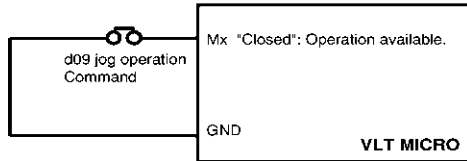

Jog operation programmed by d09 can only be initiated with the motor stopped (refer to Pr.15, Pr.16).

6. d10: Accel./Decel. Speed Inhibit – Parameter d10 programs a Multi-functional Input Terminal: M1 (Pr.38), M2 (Pr.39), M3 (Pr.40), M4 (Pr.41), M5 (Pr.42) for "hold speed" control. When the command is accepted, acceleration and deceleration is stopped and the AC drive maintains the motor at a constant speed.

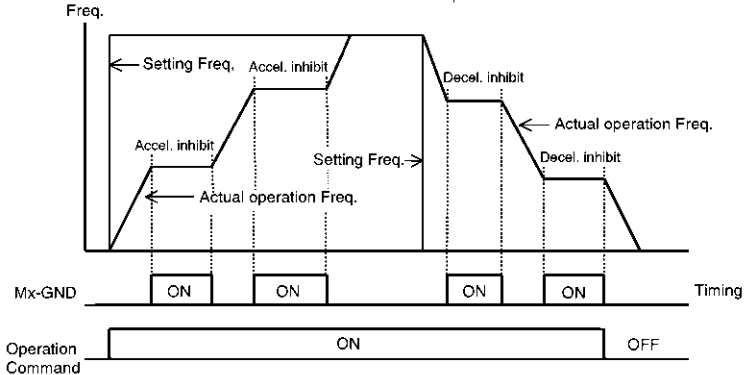

7. d11: First or Second Accel./Decel. Time Select – Parameter value d11 programs a Multi-functional Input Terminal: M1 (Pr.38), M2 (Pr.39), M3 (Pr.40), M4 (Pr.41) or M5 (Pr.42) to control selection of first or second Accel./Decel. times (refer to Pr.10, Pr.11, Pr.12, Pr.13).

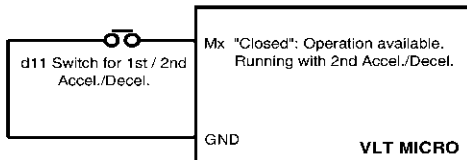

NOTE: This function is disabled when the drive is performing other functions.

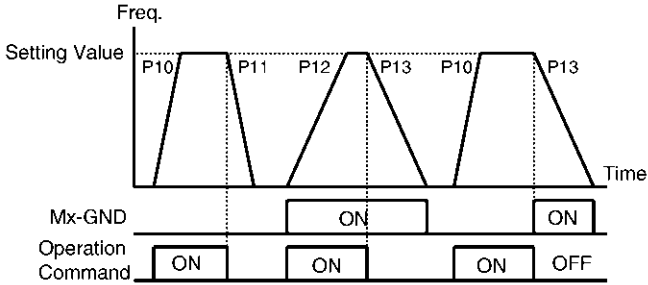

8. d12, d13: External Base Block – Parameter values d12, d13 program Multi-functional Input Terminals: M1 (Pr.38), M2 (Pr.39), M3 (Pr.40), M4 (Pr.41) or M5 (Pr.42) for external Base Block control. Value d12 is for normally open (N.O.) input, and value d13 is for a normally closed input (N.C.).

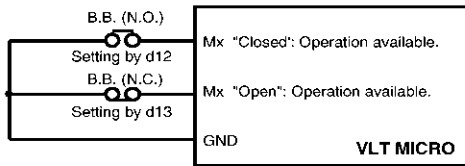

Application Note:

When the programmed inputs for d12 or d13 are used to activate base block control, the motor will free run. When base block control is deactivated, the AC drive will start its speed search function and synchronize with the motor speed then accelerated to programmed frequency.

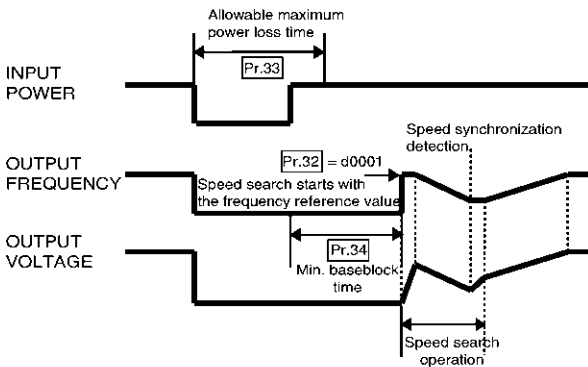

9. **d14, d15: Increase/Decrease Output Frequency Control** – Parameter value d14 programs a Multi-function Input Terminal: M1 (Pr.38), M2 (Pr.39), M3 (Pr.40), M4 (Pr.41) or M5 (Pr.42) to incrementally increase the AC drive output frequency by one unit each time the corresponding input is activated. Parameter value d15 programs an input to decrease the output frequency.

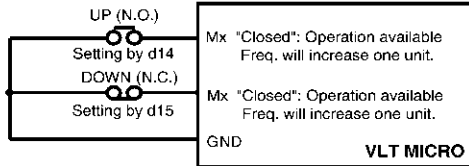

Application Note:

If the Multi-function Input Terminals programmed for Increase/Decrease Output Frequency Control (d14, d15) are asserted continuously, the output frequency will increase or decrease unit by unit continuously. If the input is pulsed, the output frequency will change one unit. This control function is enabled when the drive is running. The modified frequency is stored in non-volatile memory.

10. **d16, d17: PLC Function Control** – Parameter value d16 programs a Multi-function Input Terminal: M1 (Pr.38), M2 (Pr.39), M3 (Pr.40), M4 (Pr. 41), M5 (Pr.42) to enable the AC drive internal PLC function. Parameter value d17 programs and input terminal to pause the PLC program.

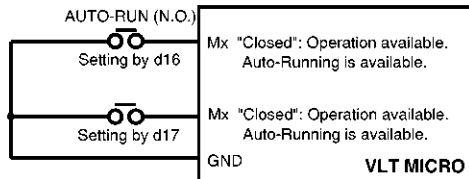

Application Note:

Parameter value d16 programs a Multi-function Input Terminal: M1 - M5 to start the internal PLC program control of the AC drive. Parameters 17 - 23, 78, 79 and 81 to 87 define the PLC program. Parameter value d17 programs an input to pause the PLC program when the input is shorted to ground. When the input terminal is not closed, the PLC program runs continuously.

12. **d18: Counter Trigger** – Parameter value d18 programs a Multi-function Input Terminal: M1 (Pr.38), M2 (Pr.39), M3 (Pr.40), M4 (Pr.41) or M5 (Pr.42) to increment the AC drive's internal counter. When the input transitions from low to high the counter is incremented by 1.

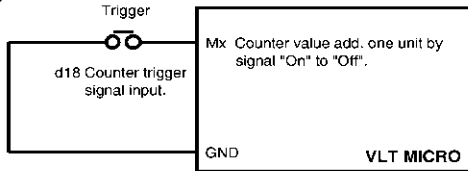

Application Note:

The Counter Trigger input can be connected to an external sensor to count a process step or unit of material used in a process. Refer to the diagram below.

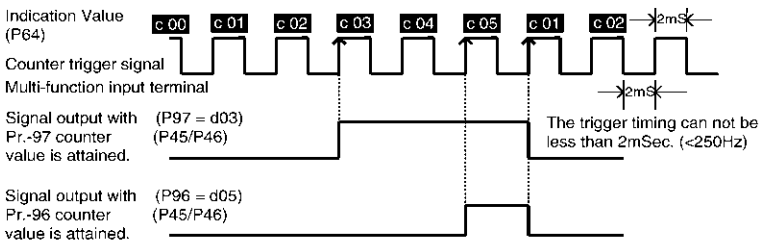

13. **d19: Counter Reset** – Parameter value d19 programs a Multi-function Input Terminal: M1 (Pr.38), M2 (Pr.39), M3 (Pr.40), M4 (Pr.41) or M5 (Pr.42) to reset the counter.

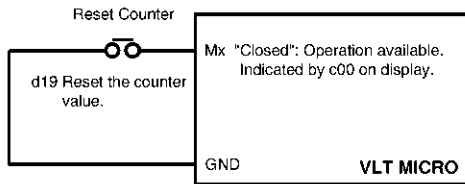

Application Note:

The input terminal resets the counter to "00" which can be displayed on the Digital Keypad/Display.

13. d20: (not used) – Parameter value d20 programs a Multi-function Input Terminal: M1 (Pr.38), M2 (Pr.39), M3 (Pr.40), M4 (Pr.41) or M5 (Pr.42) to provide no function.

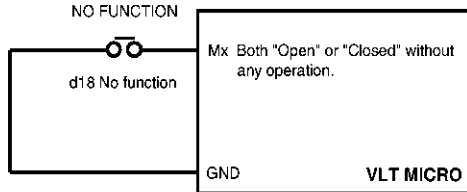

Application Note:

The purpose of this function is to provide isolation for unused Multi-function Input Terminals. Any unused terminals should be programmed to d20 to insure they have no effect on drive operation.

Pr.43 Analog Output to Drive External Meter

Factory Setting d00

Units None

Settings: d00 Analog frequency meter (0 to Maximum Frequency, Pr.03)

d01 Analog current meter (0 to 250% of the rated drive output current)

This parameter selects the AC drive output frequency or output current that will be proportional to the analog meter output signal voltage (DC: 0v - 10v).

Pr.44 Analog Output Gain (can be programmed while the drive is running)

Factory Setting d100%

Units 1%

Parameter value d01 - d200%

This function regulates voltage level of the AC motor drives analog signal output (either frequency or current output) at the AFM output terminal, which is then fed to a frequency or current indication meter.

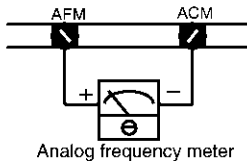

The analog voltage output is proportional to the AC drive output frequency. The AC drive's Maximum Output Frequency (Pr.03) is equivalent to 10 v DC. If required, adjust the output level using Pr.44, Analog Output Gain.

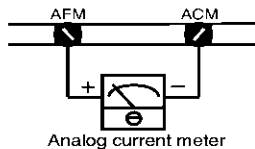

The analog voltage output is proportional to the AC drive output current. 10 v DC of analog is equivalent to 2.5 times the AC drive's Rated Output Current. If required, adjust the output level using Pr.44, Analog Output Gain.

Pr.45 Multi-function PHC Output Terminal (MO1)

Factory Setting d00
 Units None
 Settingsd00 - d14

Pr.46 Multi-function Output Relay Contact RA-RC (NO), RB-RC (NC)

Factory Setting d07
 Units None
 Settingsd00 - d14

Multi-function Output Program Values

Value	Function	Value	Function
d00	AC drive operational	d08	Desired Frequency Attained
d01	Pre-set frequency attained	d09	PLC Program Running
d02	Non-zero speed	d10	PLC Program Step Completed
d03	Over-torque detection	d11	PLC Program Execution Completed
d04	Base Block (B.B.) indicator	d12	PLC Program Execution Paused
d05	Low-voltage Detect Indicator	d13	Terminal Count Value Reached
d06	AC Drive Control Mode	d14	Preliminary Counter Value Reached
d07	Fault Indicator		

Explanation:

1. **d00: AC Drive Operational** – The Multi-function Output Terminal contacts will be "closed" when the AC drive is running or the FWD or REV command is executed.
2. **d01: Pre-set Frequency Attained** – The Multi-function Output Terminal contacts will be "closed" when the AC drive reaches the specified operating frequency defined by Pr.04.
3. **d02: Zero-speed Indicator** – The Multi-function Output Terminal contacts will be "closed" when the AC drive output frequency is less than the minimum output frequency.
4. **d03: Over-torque Detection Indicator** – The Multi-function Output Terminal contacts will remain "closed" as long as over-torque is detected. Parameter Pr.61 programs the Over-torque Detection Level. Pr.62 sets for the time limitation for over-torque before the AC drive output is turned off.
5. **d04: Base Block Indicator** – The Multi-function Output Terminal contacts will always be "closed" as long as the AC drive output is turned off.
6. **d05: Low-voltage Detect Indicator** – The Multi-function Output Terminal contacts will be "closed" when the AC drive detects a low-voltage state.

7. **d06: AC Drive Control Mode** – The Multi-function Output Terminal contacts will be "closed" when the AC drive operation is controlled by the external terminals.
8. **d07: Fault Indicator** – The Multi-function Output Terminal contacts will be "closed" when a fault is detected.
9. **d08: AC Drive Control Mode** – The Multi-function Output Terminal contacts will be "closed" when the output frequency equals the Desired Frequency attained (Pr.47).
10. **d09: PLC Program Running** – The Multi-function Output Terminal contacts will be "closed" the PLC program is executing.
11. **d10: PLC Program Step Completed** – The Multi-function Output Terminal contacts will be "closed" within 5 seconds when each multi-step speed is attained.
12. **d11: PLC Program Completed Execution** – The Multi-function Output Terminal contacts will be "closed" within 5 secs. after the PLC program completes execution.
13. **d12: PLC Program Execution Paused** – The Multi-function Output Terminal contacts will be "closed" when the PLC program execution is paused by a multi-function input terminal that has been programmed to pause the drive operation.
14. **d13: Terminal Count Reached** – The Multi-function Output Terminal contacts will be "closed" when the counter value is equal to the value programmed by Pr.96.
15. **d14: Preliminary Counter Value Reached** – The Multi-function Output Terminal contacts will be "closed" when the counter value equals the value of Pr.97.

Multi-function terminals wiring example

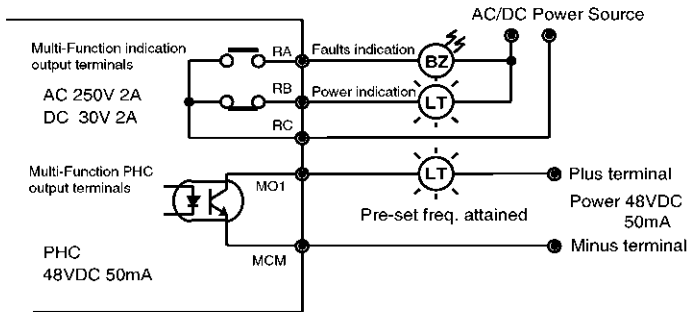

Pr.47 Desired Frequency Attained

Factory Setting d0.0 Hz

Units 0.1 Hz

Parameter value d0.0 - d400.0 Hz

Used to select a specified frequency in increments of 0.1 Hz.

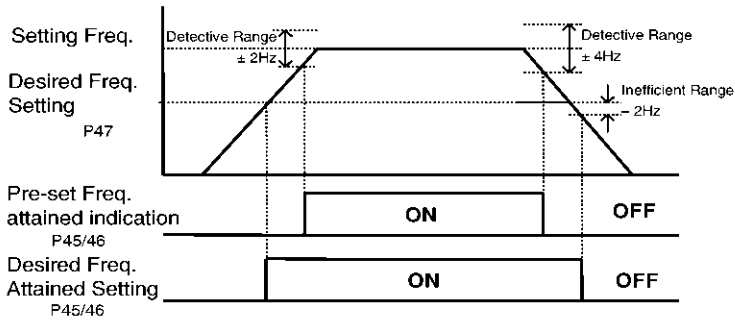
Multi-function output terminal operation (d01 and d08)

Pr.48 Output Frequency Offset (can be programmed while the drive is running)

Factory Setting d0.00

Units 0.1 Hz

Parameter value d0.0 - d350.0 Hz

Pr.49 Process Signal Bias (can be programmed while the drive is running)

Factory Setting d00

Units none

Parameter value d00 (minimum output frequency corresponds to 0 V, 4 mA)

d01 (minimum output frequency corresponds to potential bias)

Pr.50 Process Signal Gain

Factory Setting d100

Units 1%

Parameter value d01 - d200%

Pr.51 Process Signal Reverse Motion

Factory Setting d00

Units none

Parameter value d00 (forward motion only)

d01 (reverse motion enabled)

In the following examples the output frequency and direction of motion is controlled by a potentiometer connected to the external terminals or the potentiometer in the Digital Keypad/Display. Observe the interaction and effect of parameters: Pr.48, 49, 50, 51 on the potentiometer operation.

Example 1: The configuration in this example is the most common. Set Pr.00 to d00, d01 or d02 and select J5, J6, J7 jumper settings to control the output frequency: through potentiometer in the Digital Keypad/Display, or through the external AV1: 0-10 V, 4-20 mA.

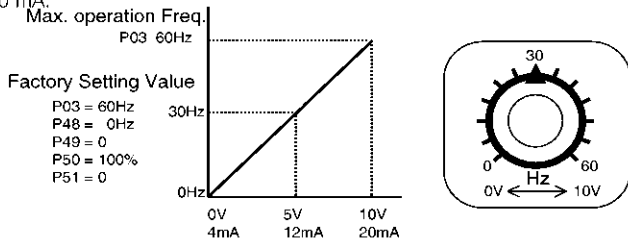

Example 2: In this example the output frequency range is 10 Hz to 60 Hz. Turning the potentiometer fully counter clockwise, corresponds to an output frequency of 10 Hz. Turning the potentiometer fully clockwise, to the stop, corresponds to 60 Hz. The midpoint corresponds to 40 Hz. The effective AV1 signals are: 0-8.33 V or 4-13.33 mA.

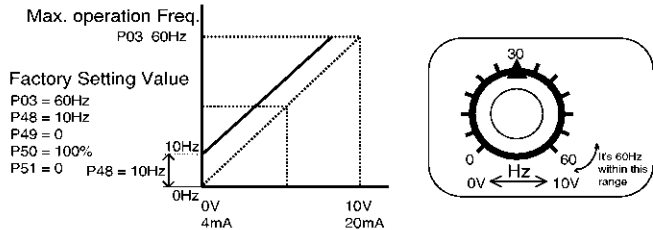

Example 3: In this example the Process Signal Gain (Pr.50) is d83%. The control range of the potentiometer is 10 - 60 hz as shown below. The corresponding range on the external AV1 terminals is: 0-10 V and 4-20 mA.

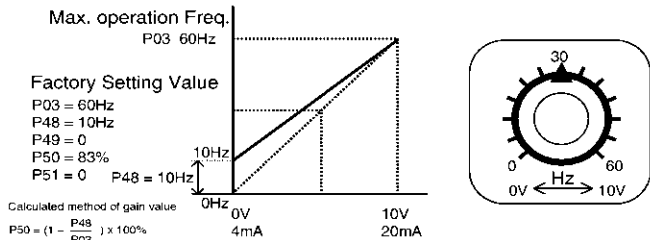

Example 4: In this example a Process Signal range of 0 to 5 V is used to control the output frequency from 0 to 60 Hz. Programming for this function can be done in two ways: 1 set Pr.50 to 200%, 2 set Pr.03 to 120 Hz, Pr.50 to 100%.

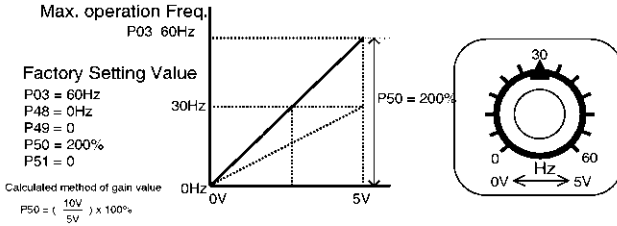

Example 5: In this example Pr.49 is set to a 1 V Process Signal bias and Pr.50 is set to 100% creating a potentiometer control voltage range of 1 to 10 V and an output frequency range of 0 to 54 Hz. This configuration is suitable for high noise environments where an external potentiometer is connected to the external AVI terminals by a cable.

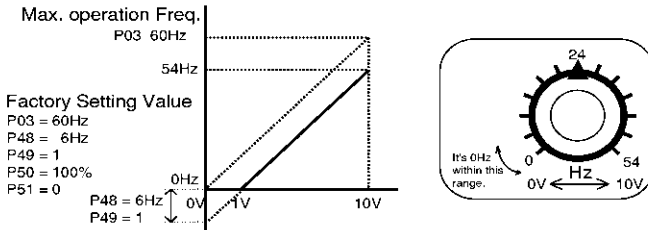

Example 6: This example is a variation of Example 5. Set Pr.50 to 110% to extend the maximum output frequency to 60 Hz. (In Example 5 the maximum output frequency is 54 Hz.)

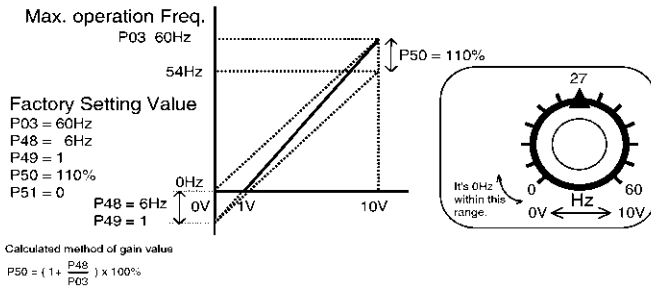

Example 7: This example is a combination of the previous 6 examples with forward and reverse motion added. Note: forward and reverse motion control is not available through the external terminals. (Refer to Pr.38-42 and Parameter values d00, d01, d02.)

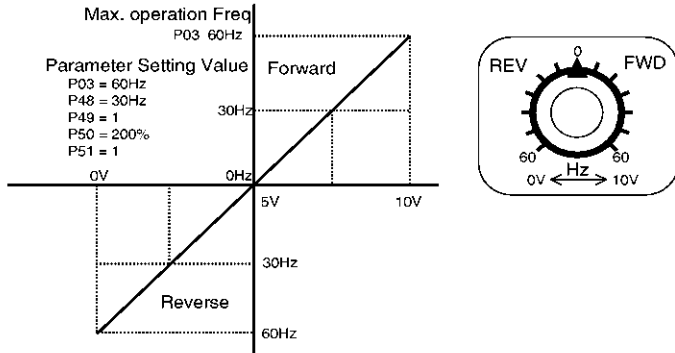

Example 8: In this example sensors are used to control the output frequency from 60 to 0 Hz. As the process signal increases from 4 to 20 mA, the output frequency decreases from 60 to 0 Hz.

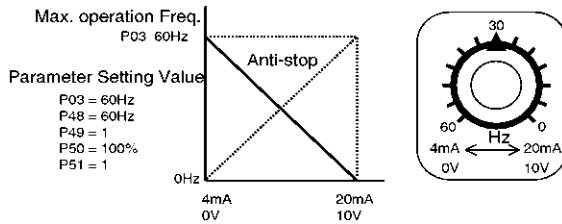

Pr.52, Pr.53 Motor Operating Specifications

Pr.52 Motor Rated Current (can be programmed while drive is running)

Factory Setting d100%
Units 1%

Parameter value d30 - d120%

This parameter must be set according to the ampere specification found on the motor nameplate. The setting will limit the AC drive output current and prevent the motor from overheating. In the event the motor current exceeds this value, the output frequency will be reduced until the motor current drops below this limit.

Pr.53 Motor No-load Current (can be programmed while drive is running)

Factory Setting d40

Units 1%

Parameter value d00 - d99%

Determines the Motor No-load Current in 1% increments. The Motor Rated Current (Pr.52) is set to 100%.

Pr.54 Torque Compensations (can be programmed while drive is running)

Factory Setting d02

Units 1%

Parameter value d00 - d10%

This parameter may be set so that the AC drive will increase its voltage output during start-up to obtain a higher initial starting torque. The additional torque will be present until the maximum operating frequency is attained.

CAUTION: Be careful when selecting the value for Pr.54. If the value is too high, the motor might overheat or be damaged.

Pr.55 Slip Compensation (can be programmed while drive is running)

Factory Setting d0.0

Units 0.1 Hz

Parameter value d0.0 - d10.0

As motor load increases, the motor slip increases. This parameter may be used to compensate for the nominal slip within a range of 0.0 - 10.0 Hz. When the output current of the AC drive is greater than the Motor No-load Current (Pr.53), the AC drive will adjust its output frequency according to value of Pr.55.

Pr.56 Special Output Display

Factory Setting d00

Units None

Settings d00 Display actual motor operation current
d01 Display DC Bus voltage

Displayed DC Bus voltage can be used to be the basis of input voltage, and is read-only.

Pr.57 Multi-function Indicator Output Contacts RA-RC (N.O.), RB-RC (N.C.)

Factory Setting d##.#

Units None

Settings None

This parameter programs the output contacts: RA-RC (N.O.) or RB-RC (N.C.) to indicate the AC drive is operating at maximum rated output current.

Pr.58, Pr.59 Electronic Thermal Overload Relay

Pr.58 De-rating for Output Current vs. Temperature

Factory Setting d02

Units None

- Settings
- d00 Active with standard motor
 - d01 Active with special motor
 - d02 Inactive

To prevent self-cooled motors from over heating when running at low speeds, program this parameter to limit the AC drive output power.

d00: The electronic thermal characteristics match a reduced torque motor (standard motor).

d01: The electronic thermal characteristics match a constant torque motor (special motor).

Pr.59 Activation Time for I²t Protection

Factory Setting d60

Units 1 Sec

Parameter value d30 - d300 Sec

This parameter programs the time required to activate the I²t electronic thermal protection function. The activation time may be defined according to short, standard and long time ratings.

Operation
time (min)

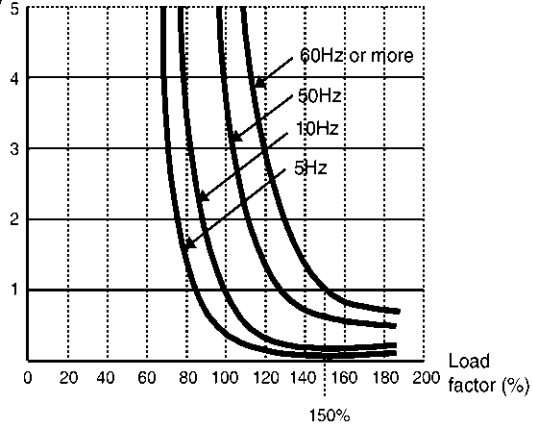

Pr.60, Pr.61, Pr.62 Over-torque Detection**Pr.60 Over-torque Detection Mode**

Factory Setting d00

Units None

Settings d00 Disabled.

d01 Over-torque Detection enabled during constant speed operation.
Drive operation continues after Over-torque Detection.d02 Over-torque Detection enabled during constant speed operation.
Drive operation halted after Over-torque Detection.d03 Over-torque Detection enabled during operation.
Drive operation continues after Over-torque Detection.d04 Over-torque Detection enabled during operation (OL2).
Drive operation halted after Over-torque Detection.

This parameter determines the AC drive's operation after Over-torque is detected. Over-torque Detection is based on the following: when the output current exceeds the Over-torque Detection Level (Pr.61, factory preset value = 150%) and the Over-torque Detection Time (Pr.62, factory setting = 0.1 second = 0.1 second, hysteresis fixed at 10%). The Multi-function PHC output 1 and 2 may be set to indicate over-torque condition. (Refer to Pr.45 and 46).

Pr.61 Over-torque Detection Level

Factory Setting d150

Units 1%

Parameter value d00 - d200%

This parameter sets the Over-torque Detection Level in 1% increments. (The AC drive rated current is defined to be 100%).

Pr.62 Over-torque Detection Time

Factory Setting d0.1 Sec

Units 0.1 Sec

Parameter value d0.1 - d10 Sec

This parameter sets the Over-torque Detection Time in units of 0.1 seconds.

Pr.63 Reserved

Pr.64 User Defined Function for Display

Factory Setting d06

Units None

Settings	d00	Displays AC drive output frequency (Hz)
	d01	Displays the user-defined setting (V, meter/sec where V = H)
	d02	Displays the user-defined setting (r):(R.P.M.)
	d03	Displays the user-defined setting (L):(Length)
	d04	Displays the user-defined setting (=):(%)
	d05	Displays the value of the internal counter (C)
	d06	Displays the setting Frequency (F)
	d07	Displays the parameter setting (P)
	d08	Reserved
	d09	Displays the motor operating current (A)
	d10	Displays Fwd./Rev. mode

The parameter can be set to display the user-defined value. (where V = H x Pr.65)

Pr.65 Coefficient of Line Speed

Factory Setting d160

Units 0.1

Parameter value d0.1 - d160

Coefficient K determines the multiplying factor for the user-defined value (v). The value of the user-defined setting (v) is calculated and displayed as follows: Display Value, v = output frequency x K. The maximum value that can be displayed is 999. If the value of "v" exceeds "999" the display value defaults to v = output frequency x 0.1.

Pr.66 Master Frequency

Factory Setting d1.0 - 400 Hz

Parameter value d0.1 - d160

Pr.67, Pr.68, Pr.69 Frequency Setting Prohibited**Pr.67, 68, 69 Skip Frequency 1, 2, 3**

Factory Setting d0.00 Hz

Units 0.1 Hz

Parameter value d0.0 - d400.0 Hz

This parameter determines the three skip frequencies which in conjunction with Pr.70, Skip Frequency Band, will cause the AC motor drives to skip operation at each frequency band. Note: Pr.67 > Pr.68 > Pr.69.

Pr.70 Frequency Bandwidth Setting Prevention

Factory Setting d0.00

Units 0.1 Hz

Parameter value d0.1 - d20.0 Hz

This parameter determines the frequency band for a given Skip Frequency. Half of the Skip Frequency Band is above the Skip Frequency and the other half is below. Programming this parameter to 0.1 disables all skip frequencies.

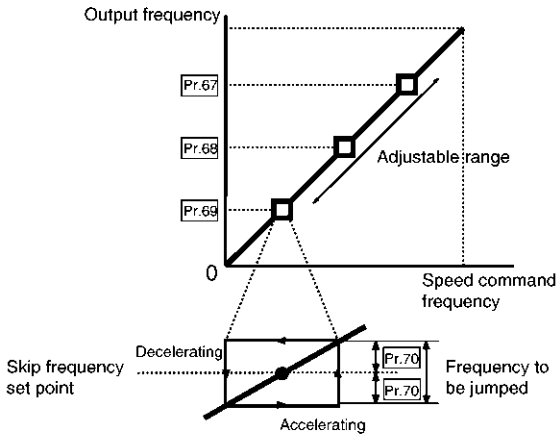

Pr.71 PWM Carrier Frequency Select

Factory Setting d15

Units 1 kHz

Parameter value d01 - d18 kHz

This parameter determines the carrier frequency for the "Pulse Width Modulated" output.

Carrier frequency	Electromagnetic noise	Noise leakage current	Heat dissipation
1kHz	large	small	small
3kHz	↕	↕	↕
9 kHz			
15 kHz	↕	↕	↕
18 kHz			

NOTE: Audible of AC motor can be reduced by using a higher carrier frequency, however please note that the rated output current of the drive decreases by 0.2A for every 1 kHz increase in carrier above 16 kHz.

Pr.72 Auto-Reset / Restart Operation Following a Fault

Factory Setting d00

Units none

Parameter value d00 - d10

Auto-Reset/Restart Operation may be performed up to 10 times after a fault has occurred. Setting the parameter to d00 disables the Reset/Restart operation after a fault has occurred. When the drive detects over current or over voltage the Auto Reset/Restart function can be selected to automatically restart the drive.

Pr.73, Pr.74, Pr.75 Three Most Recent Fault Records**Pr.73, 74, 75 The 1st, 2nd, 3rd most recent fault record**

Factory Setting d00

Units none

Settings	d00 Fault records clear (no errors occurred)
	d01 Over-current (oc)
	d02 Over-voltage (ov)
	d03 Overheat (oH)
	d04 Overload (oL)
	d05 Overload 1 (oL1)
	d06 External Fault (EF)
	d07 CPU failure 1 (CF1)
	d08 CPU failure 3 (CF3)
	d09 Hardware Protection Failure (HPF)
	d10 Over-current during acceleration (OCA)
	d11 Over-current during deceleration (OCd)
	d12 Over-current during steady state operation (OCn)
	d13 Ground fault or false failure (GFF)
	d14 Manufacturer-used diagnostics
	d15 Manufacturer-used diagnostics
	d16 Manufacturer-used diagnostics
	d17 External Base Block (bb)
	d18 Overload 2 (oL2)
	d19 Manufacturer-used diagnostics
	d20 Software protection code

Parameters: Pr.73, Pr.74 and Pr.75 store the three most recent faults that have occurred. Set these parameters to d00 to clear the fault and return the drive to service. The fault should be removed before returning the drive to service.

NOTE: Values d14, d15, d16, d17, d18 and d20 are displayed but not recorded.

Pr.76 Parameter Key

Factory Setting d00

Units None

- Settings
- d00 All parameters can always be set and read
 - d01 All parameters are read-only
 - d02-d09 Not used
 - d10 Resets all parameters to the factory defaults

This parameter controls the programming and read status for all parameters. Value d10 resets all parameters to factory settings.

Pr.77 Reserved**Pr.78 PLC (Programmable Logic Controller) Operation Mode**

Factory Setting d00

Units None

- Settings
- d00 Disable PLC program execution
 - d01 Execute one cycle of the PLC program
 - d02 Continuously execute program cycles
 - d03 Execute one cycle step by step
 - d04 Continuously execute program cycles step by step

This parameter controls PLC program execution: Pr.79 - 87.

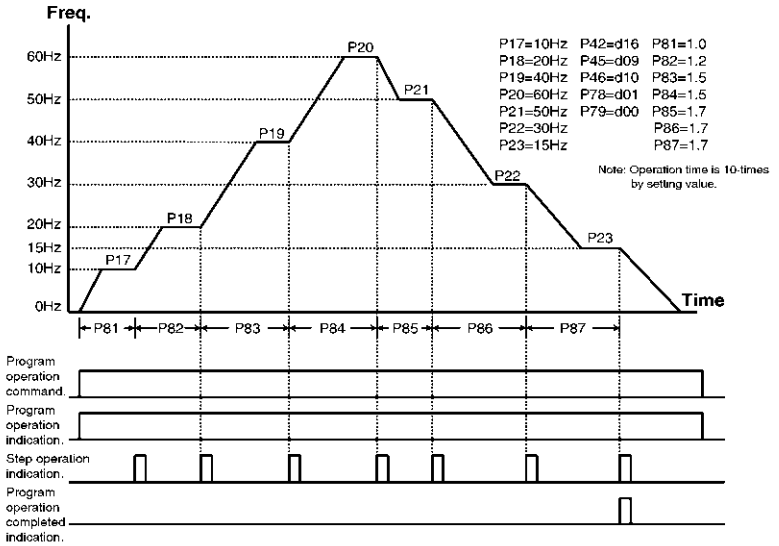
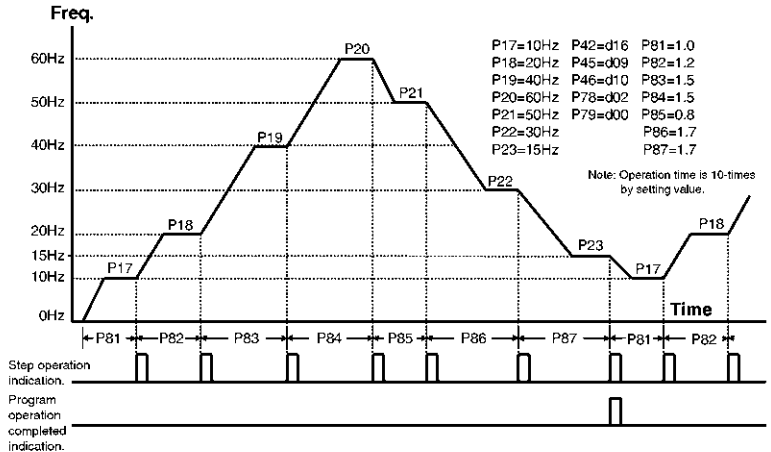
Example 1 (Pr.78 = d01): Execute one cycle through the PLC program

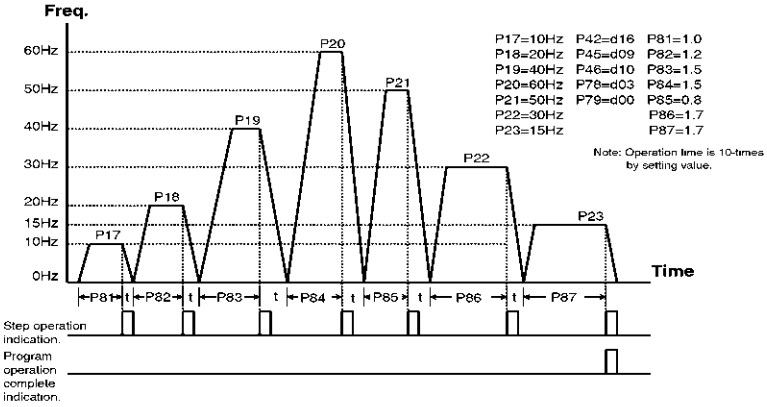
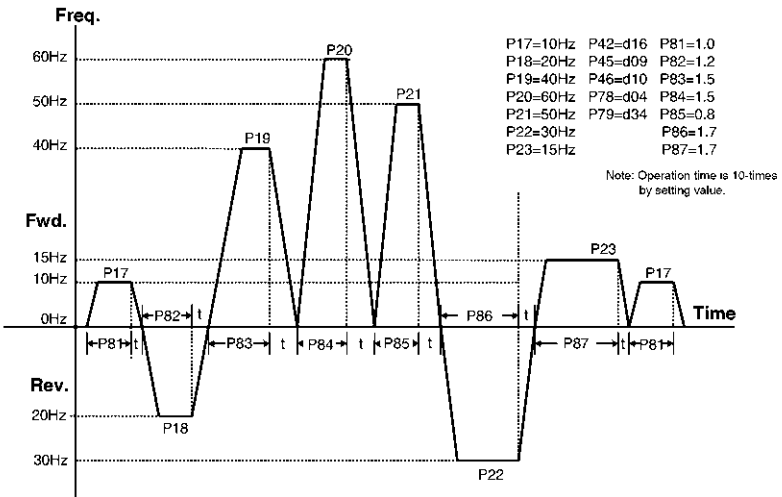
Example 2 (Pr.78 = d02): Continuously execute program cycles

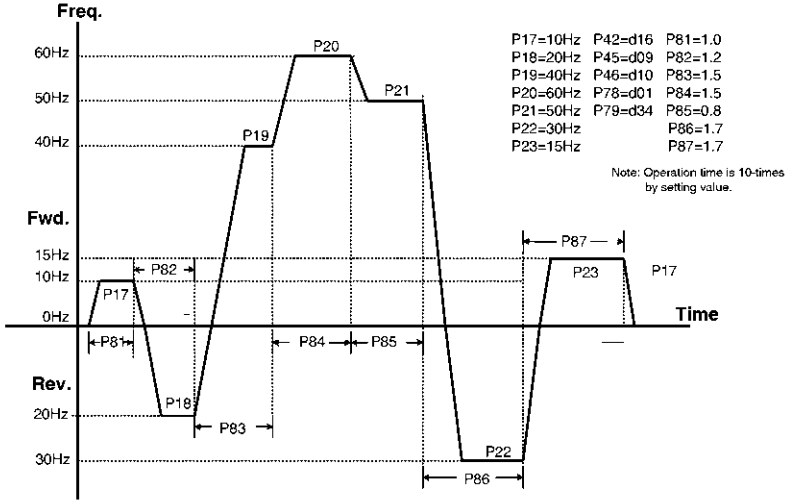
Example 3 (Pr.78 = d03): Execute one cycle step by step

Example 4 (Pr.78 = d04): Continuously execute program cycles step by step

Example 5 (Pr.78 = d01): Execute one cycle through the PLC program

Application Note:

Changing the value of Jog parameters 15 and 16 will interrupt PLC program execution. PLC program execution will not be interrupted when and other parameter values are changed.

Pr.79 PLC Forward/Reverse

Factory Setting d00
 Units None
 Settings d00 - d127

This parameter controls the direction of motion for the multi-speed parameters 17 to 23.

Explanation:

The equivalent 7-bit binary number is used to program forward/reverse motion for each of the 7 speed steps.

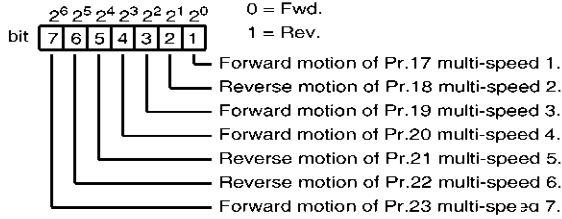

Example: parameter value = d50 equals 0110010

Setting Example:

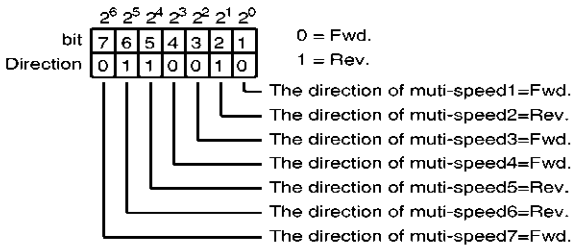

$$\begin{aligned}
 \text{Decimal value} &= \text{binary bit } 7 \times 2^6 + \text{bit } 6 \times 2^5 + \text{bit } 5 \times 2^4 + \text{bit } 4 \times 2^3 + \text{bit } 3 \times 2^2 + \text{bit } 2 \times 2^1 + \text{bit } 1 \times 2^0 \\
 &= 0 \times 2^6 + 1 \times 2^5 + 1 \times 2^4 + 0 \times 2^3 + 0 \times 2^2 + 1 \times 2^1 + 0 \times 2^0 \\
 &= 0 + 32 + 16 + 0 + 0 + 2 + 0 \\
 &= 50
 \end{aligned}$$

Setting the P79 = d50

Attached:
 $2^0 = 1$ $2^3 = 8$ $2^6 = 64$
 $2^1 = 2$ $2^4 = 16$
 $2^2 = 4$ $2^5 = 32$

Pr.80 Manufacturer Model Information

Factory Setting	d##
Units	None
Settings	d00 220V 3-Phase/1-Phase 0.5Hp d01 400V 3-Phase/1-Phase 0.5Hp d02 220V 3-Phase/1-Phase 1.0Hp d03 400V 3-Phase/1-Phase 1.0Hp d04 220V 3-Phase/1-Phase 2.0Hp d05 220V 3-Phase/1-Phase 2.0Hp d06 200V 3-Phase/1-Phase 3.0Hp d07 200V 3-Phase/1-Phase 3.0Hp

This parameter contains information on the drive: model number, firmware version, etc. (The parameter is read only).

Pr.81 ~ Pr.87 PLC Program Step Time Intervals

Factory Setting	d0.0
Units	10 Sec
Settings	d0.0 - d650

Each of the parameters: 81 to 87 control the time intervals for each Multi-speed Step defined by Pr.17 to Pr.23.

Pr.88 ~ Pr.94 Serial Communication (See Appendix D in this manual.)
Pr.95 Auto Energy-saving

Factory Setting	d00
Units	None
Settings	d00 Without energy-saving operation d01 With energy-saving operation

While enabling auto energy-saving, the AC motor drive operates at full power during acceleration/deceleration, and provides the motor optimum voltage calculated automatically based on the load power when operating at fixed rotation speed. This function is not suitable for frequent load variation or load whose operation voltage is close to its rated load.

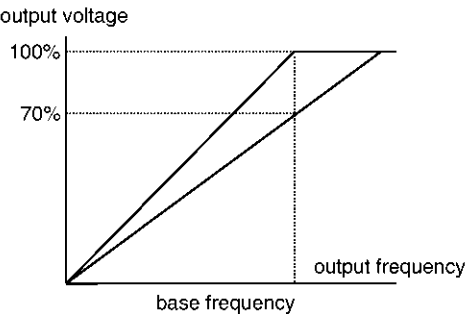

Output characteristics curve of energy-saving operation

Pr.96 Count Down Completion Settings

Factory Setting d00
Units None
Settings d00 ~ d999

This parameter defines the terminal count value for the internal counter. The counter can be incremented by a low-to-high transition on a selected Multi-Function Input Terminal: M1 or M2. Upon completion of the count, if Pr.45 is programmed to d13, the Multi-Function Output Terminal (MO1) will be closed. If Pr.46 is programmed to d13, the Multi-Function Relay Contact RA, RB, RC will be closed.

Pr.97 Preset Count Down Completion Settings

Factory Setting d00
Units None
Settings d00 ~ d999

This parameter sets a preliminary count value for the internal counter. The counter can be incremented by a low-to-high transition on one of the programmed Multi-Function Input Terminals: M1 or M2. The count starts at c01. When it reaches the preliminary count value and the selected Multi-Function Output Terminal will be closed (Pr.45 = d14). Preliminary Count can be used to initiate an external event before the "terminal count" is reached. (See Pr.38, 39, 40, 41, 42, 45, 46 for further details).

Pr.98 ~ Pr.99 Reserved**Pr.100 Software Version**

Factory Setting d###
Units None
Settings None

This parameter shows the software version of the AC motor drive, and is read-only.

Pr.101 Auto Acceleration/Deceleration Adjustment Selection

Factory Setting d00

Units None

- Settings
- d00 Linear acceleration deceleration
 - d01 Automatic acceleration, linear deceleration
 - d02 Linear acceleration, automatic deceleration
 - d03 Automatic acceleration, deceleration
 - d04 For deceleration and stall due to overvoltage

Auto acceleration/deceleration adjustment selection can reduce the mechanical vibration resulted from run and stop. When acceleration, the AC motor drive can maintain the acceleration current to its rated value, making the motor operate to the set frequency by the fastest acceleration. When decelerating, it can also judge the load regeneration automatically, and then stop the motor smoothly in the fastest deceleration time.

Using auto acceleration/deceleration selection can avoid complex regulation procedure. It performs acceleration operation without stall and deceleration stop without braking resistors. It can also improve operation efficiency effectively and save energy.

This parameter provides five modes from which to choose:

- d00 Linear acceleration deceleration
(operation at Pr.10, Pr.11 or Pr.12, Pr.13 acceleration/deceleration time)
- d01 Automatic acceleration, linear deceleration
(operation by automatic acceleration, Pr.11 or Pr.13 deceleration time)
- d02 Linear acceleration, automatic deceleration
(operation by automatic deceleration time, Pr.10 or Pr.12 acceleration time)
- d03 Automatic acceleration deceleration
(acceleration/deceleration time is completely decided by AC motor drive automatic control)
- d04 Linear acceleration/deceleration according to the time setting of parameters Pr.11 and Pr.13 auto deceleration.

The auto deceleration function is not suitable when using braking resistors.

Pr.102 Auto Voltage Regulation (AVR)

Factory Setting d00

Units None

- Settings
- d00 AVR function enabled
 - d01 AVR function disabled
 - d02 AVR function disabled when stop
 - d03 AVR function disabled for deceleration

AVR function automatically regulates the AC drive output voltage to the Maximum Output Voltage (Pr.03). For instance, if Pr.03 is set at 200 VAC and the input voltage is at 200V to 264VAC, then the Maximum Output Voltage will automatically be regarded to 200 VAC.

Without AVR function, the Maximum Output Voltage may vary between 180V to 264VAC, due to the input voltage varying between 180V to 264 VAC.

Selecting program value d2 enables the AVR function and also disables the AVR function during deceleration. This offers a quicker deceleration.

The rated voltage of motor is normally AC220/200V, 60Hz/50Hz. The input voltage of AC motor drive can be AC180V~264V, 50Hz/60Hz. Without auto voltage regulation, if the input voltage of AC motor drive is AC250V, then the voltage output to the motor is also AC250V. Under the circumstance that the motor operates with voltage in excess of rated voltage for 12%~20%, it will cause temperature increase, insulation damage and unstable torque output. In the long run, the life of the motor will be shortened.

The auto voltage regulation of AC motor drive can stabilize the output power to the motor rated voltage automatically when the output power exceeds the motor rated voltage. For example, with V/F curve set as AC200V/50Hz, if the input power is AC200V~264V, the voltage output to the motor will be stable at AC200V/50Hz, never exceeding the set voltage. If the input power varies between AC180V and AC220V, the voltage output to the motor will proportion to the input power.

When we find the motor stops with ramp type, disabling auto voltage regulation will shorten the deceleration time.

Pr.103 ~ Pr.110 Reserved

Pr.111 Deceleration S curve Setting

Factory Setting d00

Units None

Parameter value d00 ~ d7

This parameter can be set to obtain a slow stop without hard braking. The deceleration S curve will differ according to the setting value from 1-7. If there is no specific setting of this parameter, the parameter of acceleration/deceleration S curve is determined by parameter Pr.14.

When the parameter setting is d00, then the acceleration/deceleration timing is determined by parameter Pr.14. If the parameter setting is between d01 to d07, then Pr.14 is set as acceleration, and Pr.111 is deceleration.

Pr.112 External Terminal Scanning Time

Factory Setting d00

Units None

Parameter value d00 ~ d20

This function can screen and protect external terminals when the CPU mis operates due to the external disturbance. Factory setting of the scanning time is 2ms. For example: d01; 2ms, d02; 4ms, etc.

It is necessary to change the parameter Pr.77 setting to d02, in order to change the scanning time when setting this parameter.

Pr.113 Communication Mode

Factory Setting d01

Settings d01 MODBUS

This parameter is to select the communication mode, d00 is the existed Delta ASCII communication mode, whereas d01 is to select MODBUS mode.

Chapter 5
Summary of Parameters

This chapter summarizes all 10 of the parameter groups. For complete descriptions of individual parameters refer to Chapter 4.

No.	Parameter Name	Function Explanation	Parameter Value	Factory Setting
00	Master Speed Frequency Setting	Master frequency source select	d00:Master frequency input determined by the digital control panel d01:Master frequency input determined by the analog signal (DC 0 to +10 V) d02:Master frequency input determined by the analog signal (DC 4 to 20 mA)	d00
01	Operation Command Source	Operation command source select	d00:Operating instructions determined by the digital control panel d01:Operating instructions determined by the external terminal connections, keypad STOP key effective d02:Operating instructions determined by the external terminal connections, keypad STOP key not effective	d00
02	Motor stop method	Motor stop method select	d00:RAMP stop d01:Coasting to stop	d00
03	V/F Curve Setting (13 & 14)	Max output freq.	d50.0 - d400. Hz	d60.0
04		Max voltage freq.	d10.0 - d400. Hz	d60.0
05		Max output volt	d2.0 - d255.0 V *	d220.
06		Mid-point freq.	d0.1 - d400. Hz	d1.50
07		Mid-point volt	d002.0 - d255. V *	d10.0
08		Min output freq.	d0.1 - d20.0 Hz	d1.50
09		Min output volt	d2.0 - d50.0 V	d10.0
10	Accel/Decel Time Setting	Acceleration time 1	d0.1 - d600. sec	d10.0
11		Deceleration time 1	d0.1 - d600. sec	d10.0
12		Acceleration time 2	d0.1 - d600. sec	d10.0

* Twice this value for 460 V class.

No.	Parameter Name	Function Explanation	Parameter Value	Factory Setting
13		Deceleration time 2	d0.1 - d600. sec	d10.0
14	S-curve	S-curve	d00 - d07	d00
15	Jog Operation	Jog accel/decel time	d0.1 - d600. sec	d1.0
16	Setting	Jog frequency	d0.1 - d400. Hz	d6.00
17	Multi-step	Multi-step speed 1	d0.0 - d400. Hz	d0.00
18	Operation Speeds	Multi-step speed 2	d0.0 - d400. Hz	d0.00
19		Multi-step speed 3	d0.0 - d400. Hz	d0.00
20		Multi-step speed 4	d0.0 - d400. Hz	d0.00
21		Multi-step speed 5	d0.0 - d400. Hz	d0.00
22		Multi-step speed 6	d0.0 - d400. Hz	d0.0
23		Multi-step speed 7	d0.0 - d400. Hz	d0.0
24	REV run inhibit	REV run inhibit	d00:REV run enable d01:Rev run disable	d00
25	Over-volt Stall Prevention	Over-voltage stall prevention	d00:Disable over-volt stall prevent d01:Enable over-volt stall prevent	d01
26	Over-current Stall Prevention	Over-current stall prevention (during acceleration)	d50 - d200%	d170
27		Over-current stall prevention (during operation)	d50 - d200%	d170
28	DC Braking	DC braking current	d0.0 - d100%	d0.0
29		DC braking time during start-up	d0.0 - d5.0 sec	d0.0
30		DC braking time during stopping	d0.0 - d25.0 sec	d0.0
31		DC braking start-up frequency	d0.0 - d60.0 Hz	d0.0
32	Momentary Power Loss Protection	Momentary power loss operation mode selection	d00:Operation stops after momentary power loss d01:Operation continues after momentary power loss. Speed search starts with the frequency reference value. d02:Operation continues after momentary power loss. Speed search starts with the minimum frequency	d00

No.	Parameter Name	Function Explanation	Parameter Value	Factory Setting
33	Maximum allowable power loss time		d0.3 - d05.0 sec	d2.0
34	Freq Searching	Min base block time	d0.3 - d05.0 sec	d0.5
35	Function Setting	Speed search deactivation current level	d30 - d200%	d150
36	Reference Freq Upper/Low	Reference freq. upper limit	d0.1 - d400. Hz	d400.
37	Limit Setting	Reference freq. lower limit	d0.0 - d400. Hz	d0.0
38 39 40 41 42	Multi-function Input Terminal Function	Multi-func input(M1) Multi-func input(M2) Multi-func input(M3) Multi-func input(M4) Multi-func input(M5)	d00:Fwd/Stop, Rev/Stop control d01:Fwd/Rev, Run/Stop control d02:3-wire operation control mode d03:External fault: N.O. input d04:External fault: N.C. input d05:RESET control d06:Multi-step speed control 1 d07:Multi-step speed control 2 d08:Multi-step speed control 3 d09:Jog frequency control d10:Accel/decel speed inhibit d11:1st or 2nd accel/decel time d12:External baseblock (N.O.) d13:External baseblock (N.C.) d14:Up frequency command d15:Down frequency command d16:Run PLC Program d17:Pause PLC Program d18:External counter trigger input d19:Counter Reset d20:(not used)	d00 d05 d06 d07 d08
43	Analog Meter Output Select	Selects frequency or output current for display on external analog meter	d00:Analog frequency meter (0 to [maximum output frequency]) d01:Analog current meter (0-250% of the rated drive output [A])	d00
44	Analog Output Gain	Analog output gain select	d01 - d200%	d100
45	Multi-Function Output TerM.	Multi-function output term. 1 (MO1)	d00:AC drive operational	d00

No.	Parameter Name	Function Explanation	Parameter Value	Factory Setting
46		Multi-function RELAY output	d01:Pre-set frequency attained d02:Non-zero speed d03:Over-torque detection d04:Baseblock indicator d05:Low-voltage detect d06:AC drive control mode d07:Fault indicator d08:Desired frequency attained d09:PLC program running d10:PLC program step complete d11:PLC completed execution d12:PLC execution paused d13:Terminal counter reached d14:Prelim counter value reached	d07
47	Desired Freq. Attained	Desired frequency attained	d0.0 - d400.0 Hz	d0.0
48	Potentiometer Control	Potentiometer shift of output frequency	d0.0 - d350 Hz	d0.0
49		Potentiometer bias control	d00:Minimum output frequency corresponds to potentiometer at 0 V or 4 mA d01:Initial output frequency set with a potential bias point, refer to Pr.50	d00
50		Potentiometer output freq. gain	d01 - d200%	d100
51		Reverse motion setting	d00:Forward motion only d01:Reverse motion enabled	d00
52	Mtr. Operating Specifications	Motor rated current	d30 - d120%	d100
53		Motor no-load	d00 - d99%	d40
54	Torque Comp. Setting	Auto torque compensation gain	d00 - d10	d02
55	Slip Comp.	Slip compensation	d0.0 - d10.0	d0.0
56	Specific Output Display	Actual mtr. current or DC Bus voltage	d00:Display actual motor current d01:Display DC Bus voltage	d00
57	AC Drive Rated	Current Indicator		d##.##
58	Electronic Thermal Overload Relay	Select motor derating vs. temperature curves	d00:Active with standard motor d01:Active with special motor d02:Inactive	d02

No.	Parameter Name	Function Explanation	Parameter Value	Factory Setting
59	Activation Time for Electronic Thermal Protection Function		d30 - d300 sec	d60
60	Over-torque Detection	Over-torque detection mode	d00:Over-torque detection not enabled d01:Over-torque detection during constant speed operation. Drive operation halted after over-torque (OL2). d02:Over-torque detection during constant speed operation. Operation continues after over-torque detection (OL2). d03:Over-torque detection during operation. Operation continues after over-torque detection (OL2). d04:Over-torque detection during operation. Drive operation halted after over-torque (OL2).	d00
61		Over-torque detection level	d30 - d200%	d150
62		Over-torque detection time	d0.1 - d10.0 sec	d0.1
63	Reserved			
64	User Defined Parameter Displayed	Displays user defined parameter on digital keypad/display	d00:Displays the drive output frequency (H) d01:Display user-define setting (V) d02:Display user-define setting (r) d03:Display user-define setting (L) d04:Display user-define setting (%) d05:Display the counter value (c) d06:Display the program freq. (F) d07:Display the par. setting (Pr.00) d08:Reserved d09:Displays motor current (A) d10:Displays Fwd/Rev mode	d06
65	Coefficient K	Coefficient for line speed select	d0.1 - d160.	d1.0

No.	Parameter Name	Function Explanation	Parameter Value	Factory Setting
66	Master Freq.		d0.1 - 400 Hz	d1.0
67	Frequency Setting	Skip frequency 1	d0.0 - d400. Hz	d0.0
68	Prohibited	Skip frequency 2	d0.0 - d400. Hz	d0.00
69		Skip frequency 3	d0.0 - d400. Hz	d0.00
70	Freq. Band-width Setting Prevention	Skip freq. Band	d0.1 - d20.0 Hz	d0.00
71	PWM Carrier Frequency	Carrier frequency select	d0.1 - d20.0 Hz d01 - d18; fc = 1kHz ~ 18kHz	d0.00 d15
72	Auto Reset/Restart Oper. After Fault		d00 - d10	d00
73	Fault Records	Most recent fault record	d00: Fault records clear (No errors occurred)	d00
74		2nd most recent fault record	d01: Over-current (oc)	d00
75		3rd most recent fault record	d02: Over-voltage (ov)	d00
			d03: Overheat (oH) d04: Overload (oL) d05: Overload 1 (oL1) d06: External fault (EF) d07: CPU failure 1 (CF1) d08: CPU failure 3 (CF3) d09: Hardware protect failure (HPF) d10: O.C. during acceleration (oCA) d11: O.C. during deceleration (ocd) d12: O.C. during steady state (ocn) d13: Ground fault or fuse fail (GFF) d14: EEROM abnormal 2 (CF2) d15: Manufacture used diagnostics d16: Manufacture used diagnostics d17: External baseblock (bb) d18: Overload 2 (oL2) d19: Manufacture used diagnostics d20: Soft protection efficient (codE)	
76	Key Parameter	Key parameter	d00: All parameters can always be set and read d01: All parameters are read-only d02 - d09: not used d10: Resets all parameters to the factory defaults	d00
77	Auto Decel. Gain Key	Auto deceleration gain key	d00: Auto deceleration gain key d01: Able to adjust the gain value	d00

No.	Parameter Name	Function Explanation	Parameter Value	Factory Setting
78	PLC Operation Mode	PLC (programmable logic controller) operation mode	d00:Disable PLC performing d01:Execute cycle of PLC program d02:Continuously execute cycles d03:Execute cycle step-by-step d04:Continuously execute program cycles step-by-step	d00
79	PLC Fwd/Rev Control	PLC fwd/rev control	d00 - d127	d00
80	Manufacturer Information		d00:220V 1Ø/3Ø, 0.5 Hp d02:220V 1Ø/3Ø, 1.0 Hp d04:220V 1Ø/3Ø, 2.0 Hp d03:460V 3Ø, 1.0 Hp d05:460V 1Ø, 2.0 Hp d07:460V 1Ø, 3.0 Hp	d##
81	PLC Program Step Time Intervals	Timing for step 1	d0.0 - d650	d0.0
82		Timing for step 2	d0.0 - d650	d0.0
83		Timing for step 3	d0.0 - d650	d0.0
84		Timing for step 4	d0.0 - d650	d0.0
85		Timing for step 5	d0.0 - d650	d0.0
86		Timing for step 6	d0.0 - d650	d0.0
87		Timing for step 7	d0.0 - d650	d0.0
88-94 Serial Communication (See Appendix D)				
95	Auto Energy-saving	Auto Energy-saving	d00:Without energy-saving operation d01:With energy-saving operation	d00
96	Count Down Completion	Count down value setting	d00 ~ d999	d00
97	Preset Count Down Compl.	Preset count-down	d00 ~ d999	d00
98-99 Reserved				
100	Software version		Read only	d1.06
101	Auto Accel/Decel Adjustment	Auto acceleration/ deceleration adjustment select	d00:Linear accel., decel. d01:Auto accel., linear decel. d02:Linear accel., auto decel. d03: Auto accel./decel.	d00
102	Auto Voltage Regulation	Auto voltage regulation	d00:AVR function enabled d01:AVR function disabled d02:AVR function disabled when stop d03:AVR function disabled for deceleration	d00
103-110 Reserved				
111	Decel S-curve Setting		d00 ~ d7	d00
112	Ext. Term Scanning time Setting		d00 ~ d20	d00
113	Communication Mode		d01 MODBUS	d01

Chapter 6**Troubleshooting and Fault Information**

The AC motor drive has a comprehensive fault diagnosis system that includes more than 20 different alarms and fault messages. Once a fault is detected, the corresponding protective functions will be activated to turn off the AC drive output. The different AC motor drive failures may be classified as follows:

- Over Voltage / Low Voltage
- Heatsink Over Temperature
- Motor Overload
- AC motor drive Overload
- Motor Stalled
- Microprocessor Systems Failure

The three most recent faults are stored in the AC drive non-volatile memory and may be read through the digital control panel, or through the RS-485 interface on the control board.

This section provides information to guide the user in understanding the AC drive fault conditions and the related general troubleshooting procedures. A listing and description of the AC drive failures is given, along with their possible solutions. A section on general troubleshooting is also included for reference.

Important: Pressing the Reset button will not restore the AC drive to its normal operating conditions unless the fault is corrected. During any failure, the AC drive switches off and an error message will appear in the display. The last error that occurred is stored in Pr.73.

Possible Faults	Corrective Actions
<p>o.c. The over-current hardware trip circuit detects an abnormal increase in current.</p>	<p>Check the motor output power to insure it corresponds to the AC drive output power. Check wiring connections between the AC drive and motor for possible short circuits. Increase Acceleration time 1 and 2 (Pr.10, 12). Check for possible excessive loading conditions on the motor.</p>
<p>o.u. The AC drive detects that the internal DC bus voltage has exceeded its maximum allowable value.</p>	<p>Check the AC line voltage to insure it falls within the rated AC drive input voltage. Check for possible voltage transients. Bus over-voltage could also be caused by motor regeneration. Either increase the Deceleration time or add an optional braking resistor. If a braking resistor is added, check to insure the required braking power is within the specified limits of the resistor.</p>
<p>o.H. The AC drive temperature sensor detects excessive heat.</p>	<p>Ensure that the ambient temperature falls within the specified temperature range. Check ventilation holes to insure they are not obstructed. Remove any foreign objects on the heatsinks and check for possible dirty heatsink fins. Provide enough spacing for adequate ventilation.</p>
<p>L.u. The AC drive detects that the internal DC bus voltage has fallen below its min. value.</p>	<p>Check the AC line voltage to insure it falls within the rated AC drive input voltage.</p>
<p>o.L. The AC motor drive detects excessive drive output current. The AC motor drive can withstand up to 150% of the rated current for a maximum of 60 seconds.</p>	<p>Check for motor overloaded. Reduce the Torque compensation setting (Pr.54). Increase the AC drive output capacity (Pr.25 - 27).</p>

Possible Faults	Corrective Actions
<p>[o.L.1] Internal electronic overload trip: Motor is overloaded. Reduce the current level so that the drive output current does not exceed the value set by the [Motor rated current] Pr.-52.</p>	<p>Check for possible motor overload. Check electronic thermal overload settings (Pr.58, 59). Increase motor capacity.</p>
<p>[o.L.2] Motor overload (Pr.60 - 62)</p>	<p>Reduce the motor load. Adjust the over-torque detection setting to an appropriate setting.</p>
<p>[o.c.A] Over-current during acceleration: 1. Short-circuit at motor output 2. Torque boost too high. 3. Acceleration time too short. 4. AC motor drive output capacity too small.</p>	<p>1. Check for possible poor insulation at the output line. 2. Decrease the torque boost setting in Pr.54. 3. Increase the acceleration time. 4. Replace AC drive with higher output capacity.</p>
<p>[o.c.d] Over-current during deceleration: 1. Short-circuit at motor output 2. Deceleration time too short. 3. AC drive output capacity too small.</p>	<p>1. Check for possible poor insulation at the output line. 2. Increase the deceleration time. 3. Replace with an AC drive with higher output capacity.</p>
<p>[o.c.n] Over-current during steady state operation: 1. Short-circuit at motor output 2. Sudden increase in motor loading. 3. AC motor drive output capacity too small.</p>	<p>1. Check for possible poor insulation at the output line. 2. Check for possible motor binding. 3. Replace AC drive with higher output capacity.</p>
<p>[E.F.] External terminal EF-DCM goes from ON to OFF.</p>	<p>External fault.</p>

Possible Faults	Corrective Actions
<p>c.F.1 AC motor drive internal circuitry failure.</p>	<ol style="list-style-type: none"> 1. Switch off power supply. 2. Check the AC line voltage to insure it falls within the rated AC drive input voltage. 3. Switch power to the AC drive back on.
<p>c.F.2 AC motor drive E2PROM contains invalid data or can not be programmed.</p>	<p>Check the connections between the main control board and the power board. Reset drive to factory defaults (refer to Pr.76).</p>
<p>c.F.3 Internal drive internal circuitry abnormal.</p>	<p>Switch off power supply. Check the AC line voltage to insure it falls within the rated AC drive input voltage. Switch power back on.</p>
<p>G.F.F Ground fault or fuse failure: Ground fault : The AC drive output is abnormal. When the output terminal are grounded (short circuit current is 50% higher than the AC drive rated current), the AC drive power module may be damaged. The short circuit protection is provided for the AC drive, not the user.</p>	<p>Ground fault :</p> <ol style="list-style-type: none"> 1. Check the IGBT power module for damage. 2. Check for possible poor conductor insulation on the output lines.
<p>Fuse failure: A fuse failure will be displayed by the LED on the power board.</p>	<p>Fuse failure:</p> <ol style="list-style-type: none"> 1. Replace Fuse. 2. Check the IGBT power module for damage. 3. Check for possible poor insulation at the output line.
<p>b.b. External baseblock. AC drive output is turned off.</p>	<p>When the multi-function input 1 (2, 3)-DCM terminal goes from OFF to ON, the AC drive output will be turned off.</p>
<p>c.F.A Auto acceleration/deceleration adjustment mode fault.</p>	<p>Check the motor output power to insure it corresponds to the AC drive output power. Check the AC line voltage to insure it falls within the rated AC drive input voltage. Sudden increase in motor loading.</p>

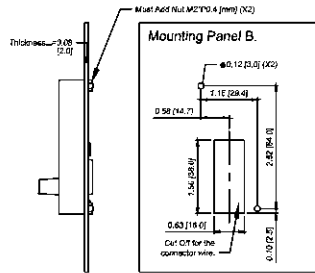
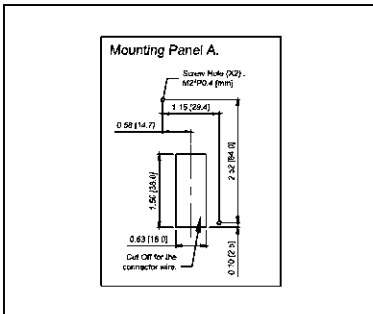
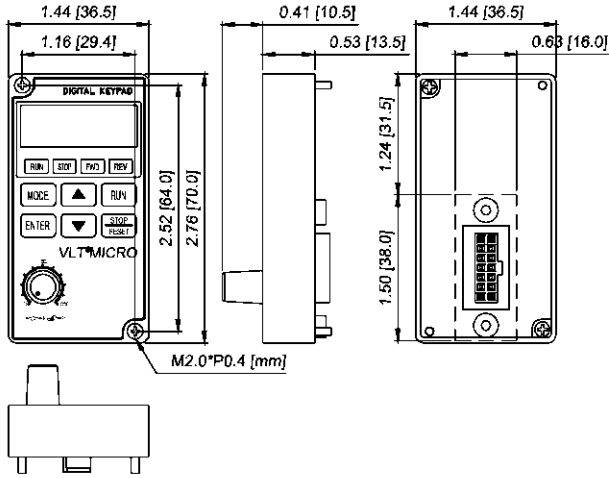
Appendix A
Dimensions: Local Control Panel (LCP)
Dimensions: Mounting Panel A and B

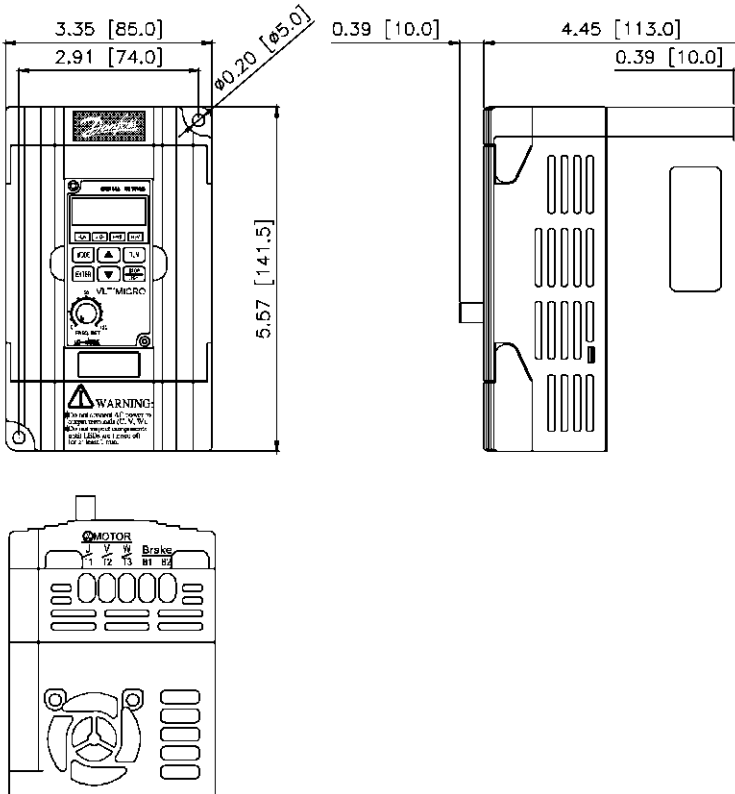
Appendix A
Dimensions 200-240V Series: 176F7300, 176F7301, 176F7302

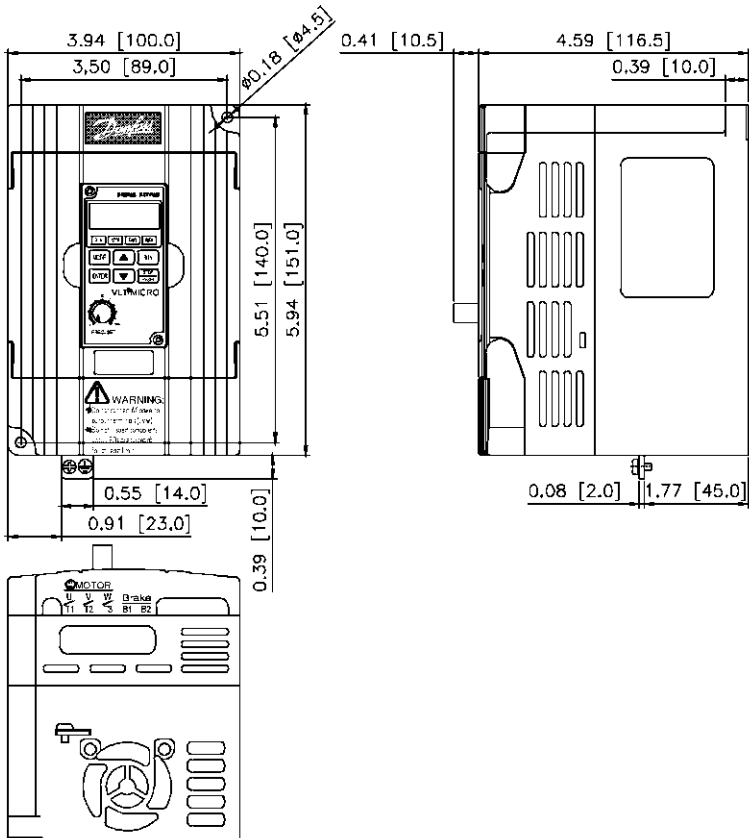
Appendix A
Dimensions 200-240V CE Series: 176F7306, 176F7307, 176F7308
Dimensions 380-480V CE Series: 176F7312, 176F7313, 176F7314

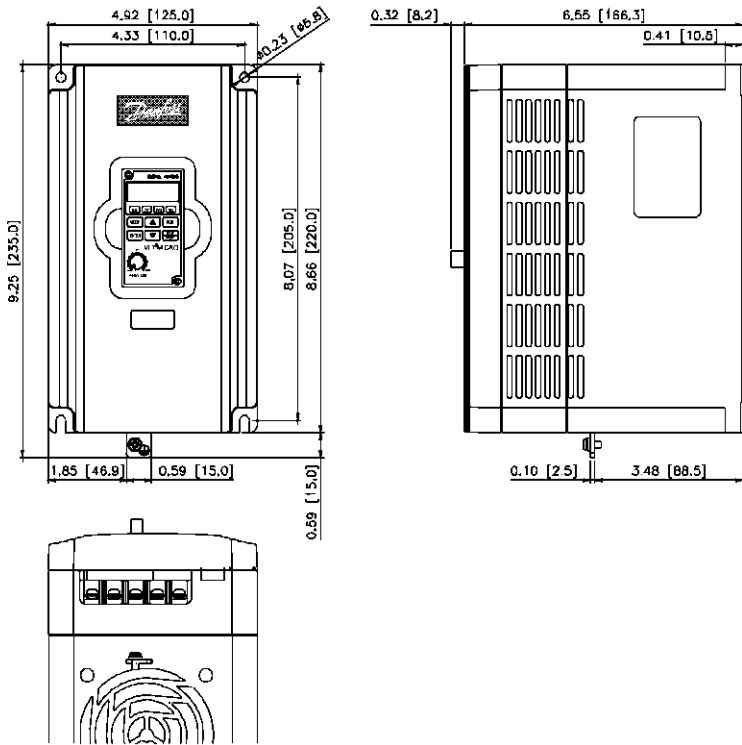
Appendix A
Dimensions 200-240V CE Series: 176F7330, 176F7331
Dimensions 380-480V CE Series: 176F7332

**Appendix B
Accessories**

Remote Keypad Kit: 6 ft. (2 meter) 176F7310
15 ft. (5 meter) 176F7325

DIN Rail Adapter Bracket Kit:
200-240V, single and three phase 176F7311
200-240V single or three phase CE 176F7315
380-460V three phase 176F7315

200-240 VAC

Brake Resistors:
0.5 HP 30% Duty Cycle 175U1003
0.5 HP 40% Duty Cycle 175U0900
0.75HP 20% Duty Cycle 175U1004
0.75HP 40% Duty Cycle 175U0901
1.0 HP 14% Duty Cycle 175U1005
1.0 HP 30% Duty Cycle 175U0989
1.0 HP 40% Duty Cycle 175U0902
2.0 HP 15% Duty Cycle 175U0992
2.0 HP 40% Duty Cycle 175U0903

380-480 VAC

Brake Resistors:
1.0 HP 10 or 14% Duty Cycle 175U1001
1.0 HP 30 or 40% Duty Cycle 175U0982
1.0 HP 40% Duty Cycle 175U0910
2.0 HP 15 or 16% Duty Cycle 175U0984
2.0 HP 40% Duty Cycle 175U0912
3.0 HP 5 or 9% Duty Cycle 175U0987
3.0 HP 40% Duty Cycle 175U0913

EMC Filter: 200-240V, 1Ø 176F7327
200-240V, 3Ø 176F7328
380-480V, 3Ø 176F7326

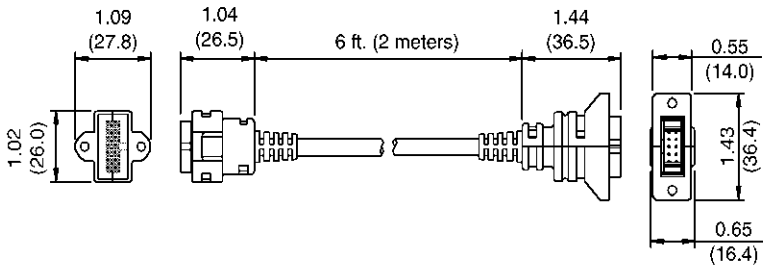
Remote Keypad Kit
6 ft. (2 meter) 176F7310
15 ft. (5 meter) 176F7325

DIN Rail Adaptor Bracket Kit :
200-240V versions 176F7311
200-240V CE versions 176F7315
380-460V CE versions 176F7315

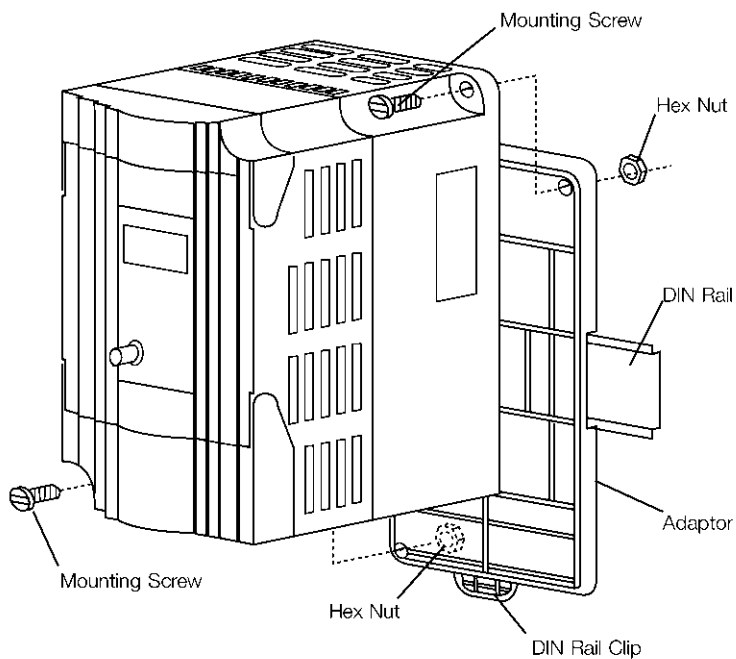

Appendix C
CE Labeling**What is CE labelling?**

The purpose of CE labelling is to avoid technical obstacles to trade within EFTA and the EU. The EU has introduced the CE label as a simple way of showing whether a product complies with the relevant EU directives. The CE label says nothing about the specifications or quality of the product. Frequency converters are regulated by three EU directives:

The machinery directive (98/37/EEC)

All machines with critical moving parts are covered by the machinery directive, which came into force on 1 January 1995. Since a frequency converter is largely electrical, it does not fall under the machinery directive. However, if a frequency converter is supplied for use in a machine, we provide information on safety aspects relating to the frequency converter. We do this by means of a manufacturer's declaration.

The low-voltage directive (73/23/EEC)

Frequency converters must be CE labelled in accordance with the low-voltage directive, which came into force on 1 January 1997. The directive applies to all electrical equipment and appliances used in the 50 - 1000 Volt AC and the 75 - 1500 Volt DC voltage ranges. Danfoss CE labels in accordance with the directive and issues a declaration of conformity upon request.

The EMC directive (89/336/EEC)

EMC is short for electromagnetic compatibility. The presence of electromagnetic compatibility means that the mutual interference between different components/appliances is so small that the functioning of the appliances is not affected.

The EMC directive came into force on 1 January 1996. Danfoss CE labels in accordance with the directive and issues a declaration of conformity upon request. In order that EMC-correct installation can be carried out, this manual gives detailed instructions for installation. In addition, we specify the standards which our different products comply with. We offer the filters that can be seen from the specifications and provide other types of assistance to ensure the optimum EMC result.

In the great majority of cases, the frequency converter is used by professionals of the trade as a complex component forming part of a larger appliance, system or installation. It must be noted that the responsibility for the final EMC properties of the appliance, system or installation rests with the installer.

Observed EMC standards**Observed emission standards**

With the use of the specified external RFI – Filter, VLT MICRO complies with the following Emission Standards up to 25m of screened/armoured motor cable, when used according to the instructions regarding EMC installation and filtering.

EN55011 class 1A

Industrial, scientific and medical (ISM) radio-frequency equipment – Radio disturbance characteristics – Limits and methods of measurement.

EN50081-2, Generic Emission Standard part 2: Industrial environment.

IEC/EN61800-3 / First environment - Restricted distribution

Adjustable speed electrical power drive systems part 3: EMC product standard including specific test methods.

**Warning!**

This is a product of the restricted sales distribution class according to IEC61800-3.

In a domestic environment this product may cause radio interference in which case the user may be required to take adequate measures.

Observed Immunity standards

VLT MICRO complies with the following Immunity Standards when used according to our instructions regarding EMC installation.

EN/IEC61000-6-2, Generic Immunity Standard part 6-2: Industrial environment.

EN/IEC61800-3 / Second environment

Adjustable speed electrical power drive systems part 3: EMC product standard including specific test methods.

Appendix D
Serial Communication**Pr.88 Communication Address**

Factory Setting d1

Settings d1 to 254

This parameter can be set during operation.

If the AC drive is controlled by RS-485 serial communication, the communication address must be set via this parameter.

Pr.89 Transmission Speed

Factory Setting d1

Settings d0 Baud rate 4800 (data transmission: bits / second)
d1 Baud rate 9600 (data transmission: bits / second)
d2 Baud rate 19200 (data transmission: bits / second)
d3 Baud rate 38400 (data transmission: bits / second)

This parameter can be set during operation.

Users can set parameters and control the operation of the AC drive via the RS-485 serial interface of a personal computer. This parameter is used to set the transmission speed between the computer and AC drive.

Pr.90 Transmission Fault Treatment

Factory Setting d3

Settings d0 Warn and keep operating
d1 Warn and stop by RAMP
d2 Warn and stop by COAST
d3 No Fault Displayed and Continue Operating

Pr.91 Over Time Detection

Factory Setting d0

Settings d0 No detection
d1 Over Time enable

Pr.92 Communication Protocol

Factory Setting d0

Settings d0 Delta ASCII/Modbus ASCII mode, <7,N,2>
d1 Delta ASCII/Modbus ASCII mode, <7,E,1>
d2 Delta ASCII/Modbus ASCII mode, <7,O,1>
d3 Delta ASCII/Modbus RTU mode, <8,N,2>
d4 Delta ASCII/Modbus RTU mode, <8,E,1>
d5 Delta ASCII/Modbus RTU mode, <8,O,1>

This parameter can be set during operation.

1 Computer Control

- There is a built-in RS-485 serial interface, marked (RJ-11 Jack) on the control terminal block. The pins are defined below:

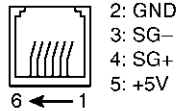

Each VLT MICRO drive has a pre-assigned communication address specified by Pr.88. The computer then controls each AC drive according to its communication address.

- The VLT MICRO can be setup to communicate on Modbus networks using one of the following modes: ASCII (American Standard Code for Information Interchange) or RTU . Users can select the desired mode along with the serial port communication protocol in Pr.92 and Pr.113.

- Code Meaning:

ASCII mode:

Each 8-bit data is the combination of two ASCII characters. For example, a 1-byte data: 64 Hex, shown as "64" in ASCII, consists of "6" (36Hex) and "4" (34Hex).

Character	"0"	"1"	"2"	"3"	"4"	"5"	"6"	"7"
ASCII code	30H	31H	32H	33H	34H	35H	36H	37H

Character	"8"	"9"	"A"	"B"	"C"	"D"	"E"	"F"
ASCII code	38H	39H	41H	42H	43H	44H	45H	46H

RTU mode:

Each 8-bit data is the combination of two 4-bit hexadecimal characters. For example, 64 Hex.

2 Data Format

2.1 10-bit character frame (For 7-bit character):

- (7, N, 2: Pr.92 = 0)

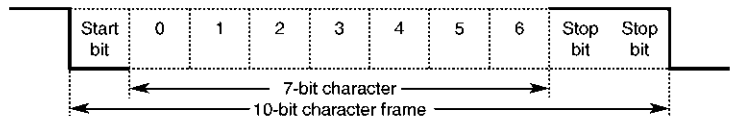

- (7, E, 1: Pr.92 = 1)

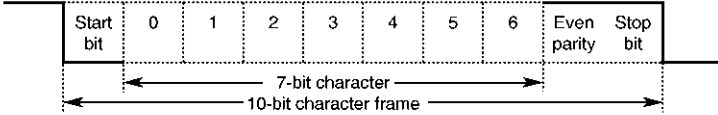

- (7, O, 1: Pr.92 = 2)

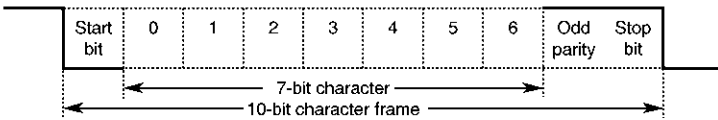

2.2 11-bit character frame (For 8-bit character):

- (8, N, 2: Pr.92 = 3)

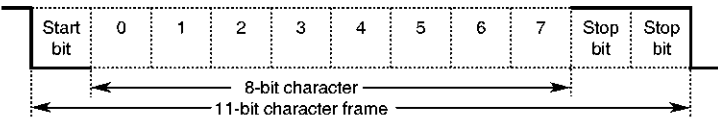

- (8, E, 1: Pr.92 = 4)

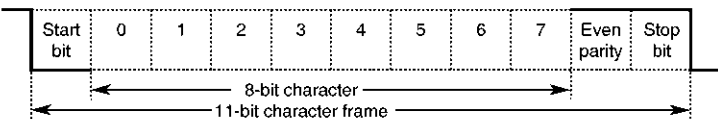

- (8, 0, 1: Pr.92 = 5)

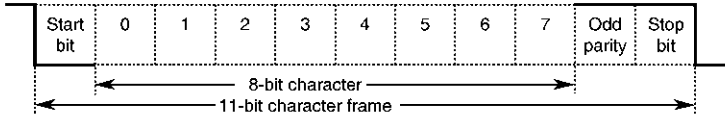

3 Communication Protocol

3.1 Communication Data Frame:

STX	ADR 1	ADR 0	CMD 1	CMD 0	0	1	N-1	N	ETX	CHK 1	CHK 0
02H	Address		CMD		Data Characters					03H	Check Sum	

3.2 ASCII mode:

STX	Start character: (3AH)
ADR 1	Communication address: 8-bit address consists of 2 ASCII codes
ADR 0	
CMD 1	Contents of data: n x 8-bit data consist of 2n ASCII codes. n 25 maximum of 50 ASCII codes
CMD 0	
DATA (n-1)	LRC check sum: 8-bit check sum consists of 2 ASCII codes
.....	
DATA 0	END characters: END 1 = CR (0DH), END 0 = LF (0AH)
LRC CHK 1	
LRC CHK 0	
END 1	
END 0	

RTU mode:

START	Asilent interval of more than 10 ms
ADR	Communication address: 8-bit address
CMD	Command code: 8-bit command
DATA (n-1)	Contents of data nx8-bit data, n<=25
.....	
DATA 0	CRC check sum: 16-bit check sum consists of 2 8-bit characters
CRC CHK Low	
CRC CHK High	A silent interval of more than 10 ms
END	

3.3 ADR (Communication Address)

Valid communication addresses are in the range of 0 to 254. Communication address equals to 0 means broadcast to all AC drives (AMD), in this case, the AMD will not reply any message to the master device.

For example, communication to AMD with address 16 decimal:

ASCII mode: (ADR 1, ADR 0)='1','0' => '1'=31H, '0'=30H

RTU mode: (ADR)=10H

00: Broadcast to all AC drives	ARD1 = 30Hex, ARD0 = 30Hex
01: To AC drive at Address 01	ARD1 = 30Hex, ARD0 = 31Hex
0F: to AC drive at Address 0F	ARD1 = 30Hex, ARD0 = 46Hex
10: To AC drive at Address 10	ARD1 = 31Hex, ARD0 = 30Hex

Maximum is 254, at Address FE

3.4 CMD (Command code) and DATA (data characters)

The format of data characters depends on the command code. The available command codes are described as followed: Command code: 03H, read N words. The maximum value of N is 12. For example, reading continuous 2 words from starting address 2102H of AMD with address 01H.

CMD0:

"0"	30Hex: Stop
"1"	31Hex: FWD + RUN
"2"	32Hex: REV + RUN
"3"	33Hex: JOG + FWD + RUN
"4"	34Hex: JOG + REV + RUN
"5"	35Hex: E.F. ON (External Fault)
"6"	36Hex: Reset
"7"	37Hex: Write Parameter
"8"	38Hex: Read Parameter
"9"	39Hex: Read Inverter Status
"A"	41Hex: Reserved
"B"	42Hex: Reserved
"C"	43Hex: Reserved
"D"	44Hex: Reserved

ASCII mode:

Command message:

STX	':'
ADR 1	'0'
ADR 0	'1'
CMD 1	'0'
CMD 0	'3'
Starting data address	'2'
	'1'
	'0'
Number of data (Count by word)	'2'
	'0'
	'0'
	'0'
LRC CHK 1	'D'
LRC CHK 0	'7'
END 1	CR
END 0	LF

Response message:

STX	':'
ADR 1	'0'
ADR 0	'1'
CMD 1	'0'
CMD 0	'3'
Number of data (Count by byte)	'0'
	'4'
Content of starting data address 2102H	'1'
	'7'
	'7'
	'0'
Content of data address 2103H	'0'
	'0'
	'0'
	'0'
LRC CHK 1	'7'
LRC CHK 0	'1'
END 1	CR
END 0	LF

RTU mode:

Command message:

ADR	01H
CMD	03H
Starting data address	21H
	02H
Number of data (count by word)	00H
	02H
CRC CHK Low	6FH
CRC CHK High	F7H

Response message:

ADR	01H
CMD	03H
Number of data (Count by byte)	04H
Content of data address 2102H	17H
	70H
Content of data address 2103H	00H
	00H
CRC CHK Low	FEH
CRC CHK High	5CH

Command code: 06H, write 1 word

For example, writing 6000(1770H) to address 0100H of AMD with address 01H.

3.5 Data characters

Giving the data format according to the request of communication interface. For example, reading address 01 as Pr.04 of AC drive. "0 & 4" are the data format.

STX	ADR 1	ADR 0	CMD 1	CMD 0	0	1	N-1	N	ETX	CHK 1	CHK 0	
02H	30H "0"	31H "1"	30H "0"	38H "8"	30H , 34H "0" , "4"						03H	33H "3"	30H "0"

ASCII mode:

Command message:

STX	'.'
ADR 0	'0'
ADR 0	'1'
CMD 1	'0'
CMD 0	'6'
Data address	'0'
	'1'
	'0'
	'0'
	'1'
	'7'
LRC CHK 1	'7'
	LRC CHK 0
END 1	CR
END 0	LF

Response message:

STX	'.'
ADR 1	'0'
ADR 0	'1'
CMD 1	'0'
CMD 0	'6'
Data address	'0'
	'1'
	'0'
	'0'
Data content	'1'
	'7'
	'7'
	'0'
LRC CHK 1	'7'
LRC CHK 0	'1'
END 1	CR
END 0	LF

RTU mode:

Command message:

ADR	01H
CMD	06H
Data address	01H
	00H
Data content	17H
	70H
CRC CHK Low	86H
CRC CHK High	22H

Response message:

ADR	01H
CMD	06H
Data address	01H
	00H
Data content	17H
	70H
CRC CHK Low	86H
CRC CHK High	22H

3.6 Chk (check sum)

Check Sum is calculated by summing up ADR to ET. For Example, reading address 01 as Pr.04 of AC drive.

STX	ADR 1	ADR 0	CMD 1	CMD 0	0	1	N-1	N	ETX	CHK 1	CHK 0
02H	30H "0"	31H "1"	30H "0"	38H "8"	30H , 34H "0" , "4"					03H	33H "3"	30H "0"

$$30H + 31H + 30H + 38H + 30H + 34H + 03H = \underline{130H}$$

ASCII mode:

LRC (Longitudinal Redundancy Check) is calculated by summing up, module 256, the values of the bytes from ADR1 to last data character then calculating the hexadecimal representation of the 2's-complement negation of the sum.

For example, reading 1 word from address 0401H of the AC drive with address 01H

STX	':'
ADR 1	'0'
ADR 0	'1'
CMD 1	'0'
CMD 0	'3'
Starting data address	'0' '4' '0' '1'
Number of data	'0' '0' '0' '1'
LRC CHK 1	'F'
LRC CHK 0	'6'
END 1	CR
END 0	LF

$01H+03H+04H+01H+00H+01H=0AH$,
the 2's-complement negation of 0AH is F6H.

RTU mode:

ADR	01H
CMD	03H
Starting address	21H
	02H
Number of data (count by word)	00H
	02H
CRC CHK Low	6FH
CRC CHK High	F7H

CRC (Cyclical Redundancy Check) is calculated by the following steps:

- Step 1: Load a 16-bit register (called CRC register) with FFFFH.
- Step 2: Exclusive OR the first 8-bit byte of the command message with the low order byte of the 16-bit CRC register, putting the result in the CRC register.
- Step 3: Shift the CRC register one bit to the right with MSB zero filling. Extract and examine the LSB.
- Step 4: If the LSB of CRC register is 0, repeat step 3, else Exclusive or the CRC register with the polynomial value A001H.
- Step 5: Repeat step 3 and 4 until eight shifts have been performed. When this is done, a complete 8-bit byte will have been processed.
- Step 6: Repeat steps 2 to 5 for the next 8-bit byte of the command message.

Continue doing this until all bytes have been processed. The final contents of the CRC register are the CRC value. **When transmitting the CRC value in the message, the upper and lower bytes of the CRC value must be swapped, i.e. the lower order byte will be transmitted first.** The following is an example of CRC generation using C language. The function takes two arguments:

```
Unsigned char* data β a pointer to the message buffer
Unsigned char length β the quantity of bytes in the message buffer
```

The function returns the CRC value as a type of unsigned integer.

```

Unsigned int crc_chk(unsigned char* data, unsigned char length){
int j;
unsigned int reg_crc=0xFFFF;
while(length--){
reg_crc ^= *data++;
for(j=0;j<8;j++){
if(reg_crc & 0x01){ /* LSB(b0)=1 */
reg_crc=(reg_crc>>1) ^ 0xA001;
}else{
reg_crc=reg_crc >>1;
}
}
}
return reg_crc;
}
    
```

3.7 Address list:

The contents of available addresses are shown as below:

Content	Address	Functions
AC drive Parameters	00nnH	00 means parameter group, nn means parameter number, for example, the address of Pr.100 is 0064H. Referencing to chapter 5 for the function of each parameter. When reading parameter by command code 03H, only one parameter can be read at one time.
Command Status monitor Read only	2000H	Bit 0-1 <ul style="list-style-type: none"> 00: No function 01: Stop 10: Run 11: Jog + Run
		Bit 2-3 <ul style="list-style-type: none"> Reserved
		<ul style="list-style-type: none"> 00: No function 01: FWD 10: REV 11: Change direction
		Bit 6-15 <ul style="list-style-type: none"> Reserved

Content	Address	Functions	
	2001H	Freq. command	
	2002H	Bit 0	1: EF (external fault) on
		Bit 1	1: Reset
		Bit 2-15	Reserved
	2100H	Error code: 00: No errors occurred 01: Over-current (oc) 03: Overheat (oH) 04: Drive overload (oL) 05: Motor overload1 (oL1) 06: External fault (EF) 07: CPU failure (cF1) 08: CPU or analog circuit failure (cF3) 09: Hardware protection failure (HPF) 10: Current exceeds 2 times rated current during accel (ocA) 11: Current exceeds 2 times rated current during decel (ocd) 12: Current exceeds 2 times rated current during steady state operation (ocn) 13: Ground Fault (GF) 14: Low voltage (Lv) 15: Reserved 16: CPU failure 1 (cF2) 17: Base block 18: Overload (oL2) 19: Auto accel/decel failure (cFA) 20: Software protection enable (codE)	
		Status of AC Drive	
		Bit 0-1	00: RUN LED light off, STOP LED light up
			01: RUN LED blink, STOP LED light up
			10: RUN LED light up, STOP LED blink
			11: RUN LED light up, STOP LED light off
		Bit 2	01: Jog active
		Bit 3-4	00: REV LED light off, FWD LED light up
	01: REV LED blink, FWD LED light up		
10: REV LED light up, FWD LED blink			
11: REV LED light up, FWD LED light off			
Status monitor Read only	2101H	Bit 5-7	Reserved
		Bit 8	1: Main freq. Controlled by communication
		Bit 9	1: Main freq. Controlled by external terminal
		Bit 10	1: Operation command controlled by communication

Content	Address	Functions	
		Bit 11	1: Parameters have been locked
		Bit 12	0: Stop 1: Run
		Bit 13	1: Jog command
		Bit 14-15	Reserved
	2102H	Frequency command F (XXX.XX)	
	2103H	Output Frequency H (XXX.XX)	
	2104H	Output Current A (XXX.XX)	
	2105H	DC-BUS Voltage U (XXX.XX)	
	2106H	Output Voltage E (XXX.XX)	
	2107H	Step number of Multi-Step Speed Operation	
	2108H	Time of PLC Operation	
	2109H	Value of External Trigger	
	210AH	Power factor $\times 0.03 = \cos^{\circ}$	
	210BH	Reserved	
	210CH	Reserved	
	210DH	Reserved	
	210EH	Reserved	
	210FH	Reserved	
	2110H	Software Version	

3.8 Communication program of PC:

The following is a simple example of how to write a communication program for Modbus ASCII mode on a PC by C language.

```
#include<stdio.h>
#include<dos.h>
#include<conio.h>
#include<process.h>
#define PORT 0x03F8 /* the address of COM1 */
/* the address offset value relative to COM1 */
#define THR 0x0000
#define RDR 0x0000
```

```
#define BRDL 0x0000
#define IER 0x0001
#define BRDH 0x0001
#define LCR 0x0003
#define MCR 0x0004
#define LSR 0x0005
#define MSR 0x0006

unsigned char rdat[60];
/* read 2 data from address 2102H of AC drive with address 1 */
unsigned char tdat[60]={':','0','1','0','3','2','1','0','2','0','0','0','2','D','7','V','\n'};

void main(){
  int i;
  outputb(PORT+MCR,0x08); /* interrupt enable */
  outputb(PORT+IER,0x01); /* interrupt as data in */
  outputb(PORT+LCR,(inportb(PORT+LCR) | 0x80));
  /* the BRDL/BRDH can be access as LCR.b7==1 */
  outputb(PORT+BRDL,12); /* set baudrate=9600, 12=115200/9600*/
  outputb(PORT+BRDH,0x00);
  outputb(PORT+LCR,0x06); /* set protocol, <7,N,2>=06H
<7,E,1>=1AH, <7,O,1>=0AH
<8,N,2>=07H, <8,E,1>=1BH
<8,O,1>=0BH */
  for(i=0;i<=16;i++){
    while(!(inportb(PORT+LSR) & 0x20)); /* wait until THR empty */
    outputb(PORT+THR,tdat[i]); /* send data to THR */
  }
  i=0;
  while(!kbhit()){
    if(inportb(PORT+LSR) & 0x01){ /* b0==1, read data ready */
      rdat[i++]=inportb(PORT+RDR); /* read data form RDR */
    } } }
}
```

4 AC Drive Responding Mode:

4.1 When CMD1 is Mirror Telegram, AC drive will respond to the original command.

4.2 When CMD0 is Read Parameter, AC drive will respond.

STX(02H) + ADR(1,0) + CMD(1,0) + 8 Data Characters + EXT + CHK(1,0)

8 Data Characters:

- 2 ASCII characters as parameter.
- 2 ASCII characters as parameter number.
- 4 ASCII characters as parameter setting value.

4.3 When CMD0 is Read Inverter Status, AC drive will respond.

STX(02H) + ADR(1,0) + CMD(1,0) + 34 Data Characters + EXT + CHK(1,0)

34 Data Characters:

- 2 ASCII characters as Error Code
- 2 ASCII characters as LED
- 4 ASCII characters as frequency command (FXX.XX)
- 4 ASCII characters as output frequency (HXX.XX)
- 4 ASCII characters as output current (AXX.XX)
- 4 ASCII characters as DC-BUS voltage
- 4 ASCII characters as output voltage
- 2 ASCII characters as multi-step speed
- 4 ASCII characters as operational time
- 4 ASCII characters as counter value

5 AC Drive Communication Error:

The AC drive receives the messages, but detect a communication error, thus no response is returned. But there will be an error message "CExx" displayed on the keypad. The master device will eventually process a time out condition. The "xx" of CExx" is a decimal code, the meaning of the error message is as follows:

Error Message	Meaning
bit 0	IC 75176 or CPU communication port damaged
bit 1	Data out of range (check whether the input data are out of range)
bit 2	Character Frame Error (check whether the Baud rates comply with data frame)
bit 3	Check Sum Error (make sure the Check Sum is correct)
bit 4	Transmission Time Out
bit 5	Transmission Bus Error (The time interval between commands is too short.) Please keep an interval of 10 ms at least after the return of a command. If there is no command returned, also keep an interval of at least 10 ms for the same reason.
bit 6	Reserved
bit 7	Reserved