

## 1. General information



CLP674-085 and CLP674-137 multipurpose pumps are specifically designed for metering, injecting and transferring various chemicals, liquids, additives and other hard-to-handle fluids into production pipeline systems, gas wells and oil wells.

Danfoss CLP pumps are based on the axial piston principle offering long life and high efficiency in the demanding Oil and Gas industry. Danfoss CLP pumps have the smallest footprint on the market.

All parts are designed to provide long service life, i.e. long service life with a constantly high efficiency and minimum of service required. Lubrication of the moving parts in the pumps is provided by the fluid itself. No oil lubrication is thus required.

The pumps are fixed displacement pumps in which the flow is proportional to the number of revolutions of the input shaft and the pump displacement, regardless of any counter-pressure.

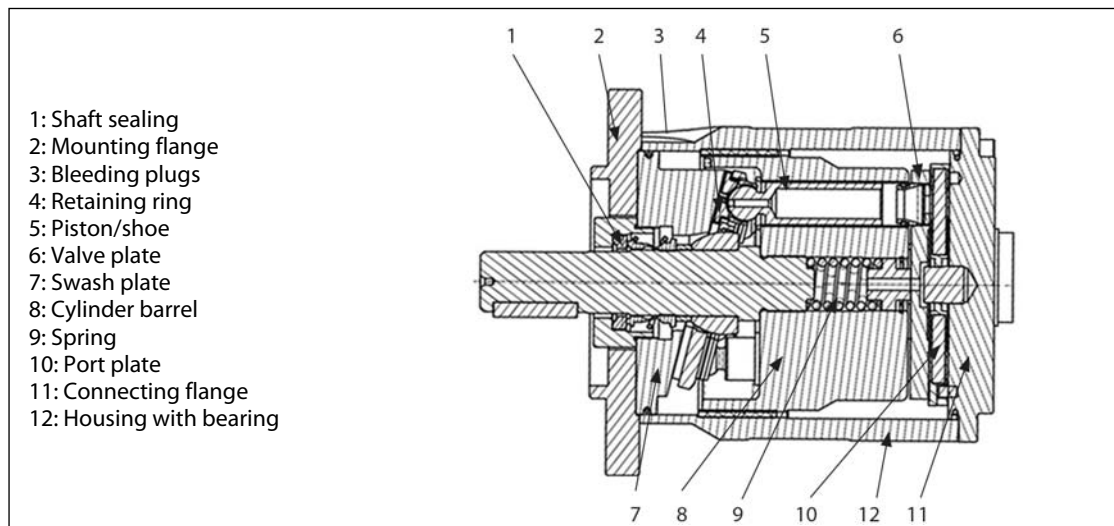

## 2. Benefits

- Constructed to provide maximum reliability with seal-less performance.
- Designed for a wide range of corrosive, volatile, expensive and other hard-to-handle fluids.
- No periodic service like e.g. change of lubricant and wearing parts.
- All parts are made of Duplex (SAF 2205/EN1.4462) and Super-duplex (SAF 2507/EN1.4410) and carbon reinforced PEEK.
- No preventive maintenance required (no periodic service like e.g. change of lubricant and wearing parts).
- Long service life and easy maintained. No oil lubrication is required
- Generates insignificant pulsations in the pressure line.
- One of the smallest and lightest pumps on the market with high efficiency.

### 3. Technical data

CLP674 [1]		CLP674(N,P,H)-085			CLP674(N,P,H)-137		
		N: 180B7079	P: 180B7080	H: 180B7081	N: 180B7086	P: 180B7087	H: 180B7088
Capacity	l/h	1700 - 5100			2733 - 8220		
	gph	447 - 1342			719 - 2157		
Geometric displacement	cm <sup>3</sup> /rpm	50			80		
	in <sup>3</sup> /rpm	3.05			4.88		
Min. pressure [3]	bar	20	60	130	20	60	130
	psi	290	870	1885	290	870	1885
Max. pressure, cont. [4]	bar	70	140	210	70	140	210
	psi	1000	2000	3000	1000	2000	3000
Max. speed cont. [5]	rpm	1800			1800		
Min. speed cont.	rpm	700			700		
Power requirement @ 80 bar, 3000 rpm:	kW	13.7			21.7		
	hp	18.4			29.1		
Weight	kg	32			32		
	lb	70.5			70.5		

[1] N = 70 bar (1000 psi), P= 140 bar (2000 psi), H = 210 bar (3000 psi)

[2] Standard seal material is NBR, for other materials please contact Danfoss Oil&Gas sales organization

[3] For lower pressure, please contact Danfoss Oil&Gas sales organization

[4] For higher pressure, please contact Danfoss Oil&Gas sales organization

[5] For speeds above 1500 rpm the CLP674 pump must be boosted at a pressure of 2-5 bar (29-72.5 psi).

### 4. Flow at different rpm

Using the diagram shown below, it is easy to select the pump which fits the application best if the flow required and the rotation speed (rpm) of the pump are known.

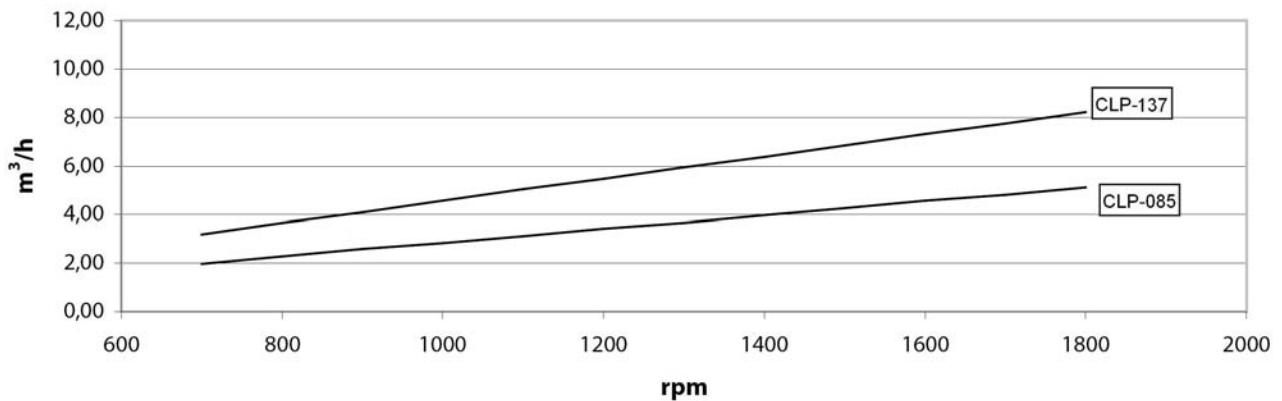

Furthermore, this diagram shows that the flow can be changed by changing the rotation speed of the pump. The flow/rpm ratio is constant, and the 'desired' flow can be obtained by changing the rotation speed to a corresponding value. Thus, the required rpm can be determined as:

$$\text{Required rpm} = \frac{\text{Desired flow} \times \text{Rated rpm}}{\text{Rated flow}}$$

## 5. Power requirements

Pump model	Flow			Pressure			rpm	Calc. factor
				60 bar	70 bar	80 bar		
	l/min	m <sup>3</sup> /h	gpm	870 psi	1015 psi	1160 psi		
CLP674-085	66	4.0	17.4	8.3 kW	9.7 kW	11.1 kW	1460	475.2
CLP674-085	79	4.7	20.9	10.0 kW	11.7 kW	13.4 kW	1752	475.2
CLP674-137	106	6.4	28.1	12.7 kW	14.8 kW	16.9 kW	1470	502.2
CLP674-137	128	7.7	33.7	15.3 kW	17.8 kW	20.3 kW	1764	502.2

The power requirements can be determined using one of the following guiding equations:

$$\text{Required power} = \frac{\text{l/min} \times \text{bar}}{\text{Calc. factor}} [\text{kW}] \quad \text{or} \quad \frac{16.7 \times \text{m}^3/\text{h} \times \text{bar}}{\text{Calc. factor}} [\text{kW}] \quad \text{or} \quad \frac{0.26 \times \text{gpm} \times \text{psi}}{\text{Calc. factor}} [\text{kW}]$$

1 hp	=	0.75 kW
1 kW	=	1.34 hp
1 gpm	=	3.79 l/min
1 l/min	=	0.26 gpm
1 m <sup>3</sup> /h	=	4.40 gpm
1 gpm	=	0.23 m <sup>3</sup> /h

## 6. Inlet pressure

Liquid supply to the pump is either made from a tank placed above the pump or directly from a feed pump. The pressure at the pump inlet (l) must be in the range: 0.5 - 7 bar (7.3 - 101.5 psi).

## 7. Noise level

The table indicates the **approximate** noise level in dB(A) measured at a distance of 1 m from the pump in a reverberation room.

Type	60 bar (870 psi)	60 bar (870 psi)
	1500 rpm	1800 rpm
CLP674-085	74	79
CLP674-137	74	79

Since the pump is typically mounted on a bell housing or frame, the noise level can only be determined for the complete unit (system).

It is therefore very important that the pump is mounted correctly on a frame with dampers to minimize vibrations and noise.

The noise level is influenced by:

- The speed of the pump, high rpm create more noise than low rpm
- Rigid mounting of the pump generates more noise than flexible mounting
- Pipe mounting direct to the pump increases the noise level compared to a flexible hose

## 8. Filtration

As many chemicals has very low viscosity, the CLP pumps have been designed with very narrow clearance in order to control internal leakage rates and improve component performance. Therefore it is important that the inlet liquid is filtered properly to minimize the wear of the pump.

The main filter must have a filtration efficiency of 99.98% at 10 µm. We recommend that you use precision depth filter cartridges rated 10µm abs. β10>5000 (equivalent to a filtration efficiency of 99.98%). Bag filters and string wound filter cartridges typically have only 90% filtration efficiency. This means that for each 100,000 particles reaching the filter, 10,000 particles pass through it compared to only 20 particles in a filter with an efficiency of 99.98%.

For more information on the importance of proper filtration, please consult our publication "Filtration" (code number 521B0861), which also will provide you with an explanation of filtration definitions and a guidance on how to select the right filter.

## 9. Pump dimensions

Dimensions with flange connection:

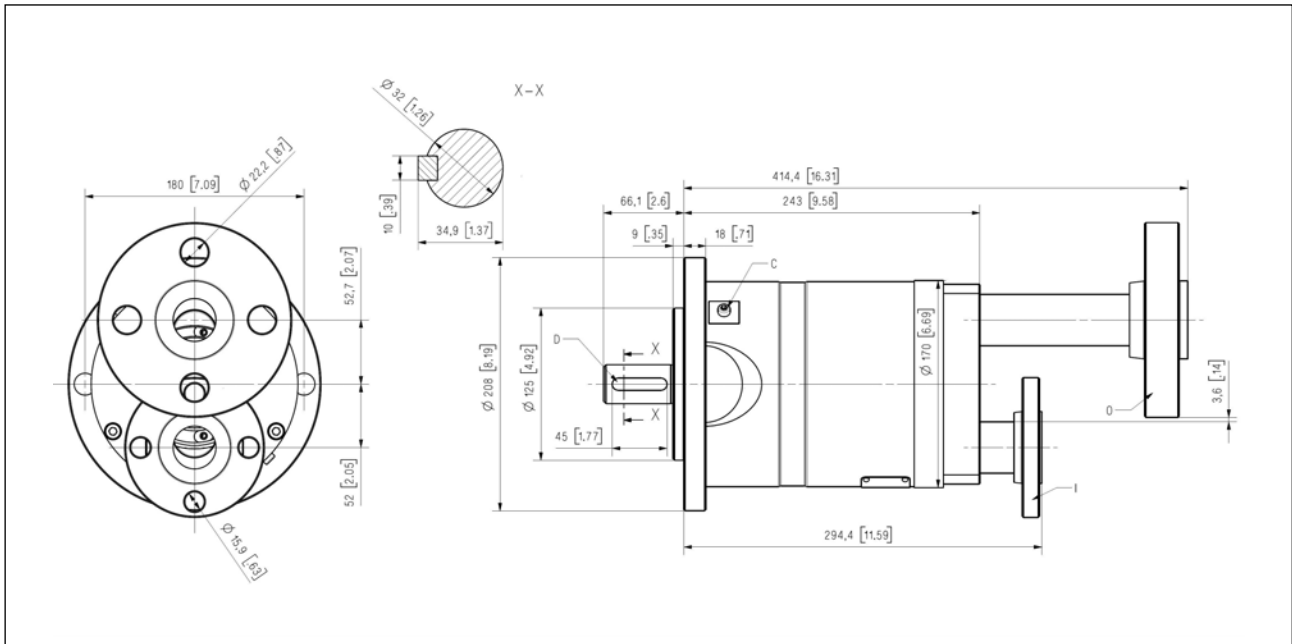

Description		CLP674-085 (N,P,H)	CLP674-137 (N,P,H)
C	Bleeding	M6, Hexagon AF = 5 mm	M6, Hexagon AF = 5 mm
D	Parallel key, DIN 6885, mm (in)	12 × 8 × 70 (0,44 × 0,31 × 2,76)	12 × 8 × 70 (0,44 × 0,31 × 2,76)
G		1 ¼" - sch. 40	1 ¼" - sch. 40
I	Inlet	1 ¼" - sch 40 ASME B16.5 flange class 150#	1 ¼" - sch. 40 ASME B16.5 flange class 150#
O	Outlet	1 ¼" - sch. 40 ASME B16.5 flange class 1500#	1 ¼" - sch. 40 ASME B16.5 flange class 1500#
Pump mounting flange		125 A2	125 A2

## 10. Installation

### 10.1 Mounting

The figure below illustrates how to mount the pump and connect it to electric motor/combustion engine.

- A: Flexible coupling
- B: Bell housing
- C: Motor shaft

If magnetic drive is required, please contact Danfoss Oil&Gas sales organization for further information.

To ensure easy mounting of the flexible coupling without using tools, the tolerances must be dimensioned accordingly.

**Note: Any axial and/or radial loads on the shaft must be avoided, see "User guide" (521B0888).**

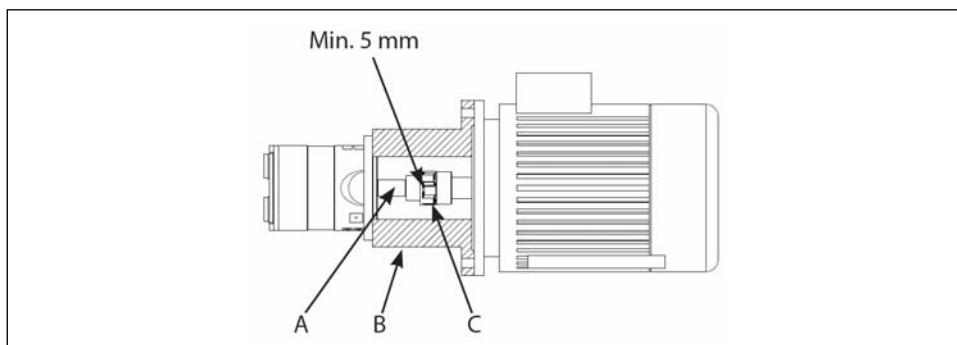

## 10.2 Open-ended systems with supply from tank

In order to eliminate the risk of cavitation, a positive inlet pressure should always be maintained by observing the following guidelines:

1. Place the tank (1) above pump inlet (level in tank should always be above the pump).
2. Place a filter (2) in the supply line in front of the tank.
3. Dimension the inlet line (3) with minimum pressure drop (large internal diameter, minimum length of pipe, avoid bends and fittings with small internal diameter).

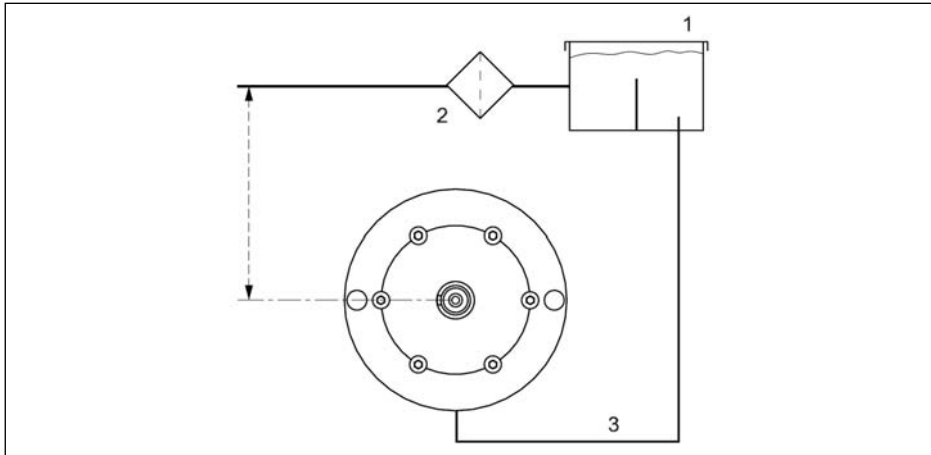

## 10.3 Open-ended system with direct supply

In order to eliminate the risk of pump cavitation, a positive inlet pressure is always to be maintained at min. 0.5 bar (7.3 psi) and max. 7 bar (101.5 psi).

1. Place the filter (1) in the supply line in front of the pump.
2. Place a monitoring pressure switch (2) set at min. 1 bar (14.5 psi) between filter and pump inlet. The monitoring switch must stop the pump at pressures lower than 1 bar. (14.5 psi) At speeds above 1500 rpm - use 2 bar (29 psi) as set point.

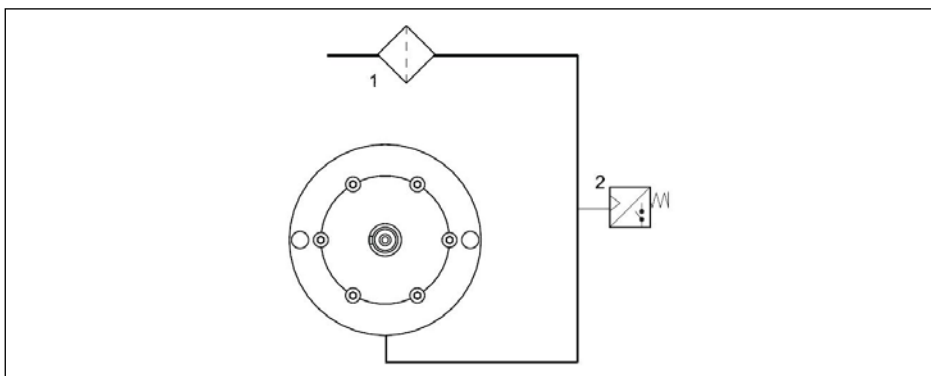

## 11. Service

The pump must be running according to the Danfoss specifications on pre-filtration, pressure, and rotation speed. To prevent a total and disastrous breakdown, Danfoss recommends a pump inspection after 1500 hours – at which any worn parts must be replaced.

**Note: It is recommended to replace pistons and shaft sealing if another service-free period is to be obtained.**

If the pistons are not replaced, more frequent inspection is recommended.

The CLP pump is made of duplex/super duplex materials with fine corrosion properties. However, it is always recommended to flush the pump when the system is shut down.

The shaft sealing in the CLP pump is made of AISI 316. At high fluid temperature, the service life of the shaft sealing can be reduced. For these applications it is recommended to replace the shaft sealing after approx. 1000 hours operation.

### 11.1 Periodic maintenance

The pumped fluid act as lubricant in the CLP. Thus there is no oil in the pump.

### 11.2 Repair

In case of irregular function of the CLP, please contact the Danfoss Oil&Gas sales organisation.

Danfoss can accept no responsibility for possible errors in catalogues, brochures and other printed material. Danfoss reserves the right to alter its products without notice. This also applies to products already on order provided that such alterations can be made without subsequential changes being necessary in specifications already agreed. All trademarks in this material are property of the respective companies. Danfoss and the Danfoss logotype are trademarks of Danfoss A/S. All rights reserved.



DK-6430 Nordborg  
Denmark