

Drives 101

Lesson 5

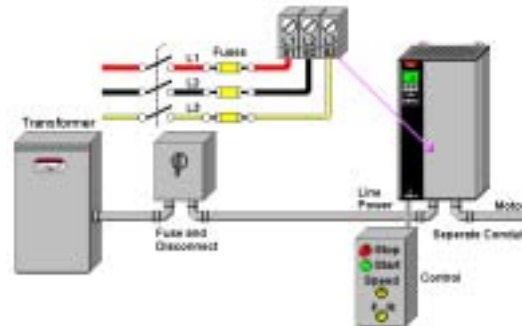

Power Input Terminology for a AFD



This lesson covers the terminology associated with the incoming power to a Adjustable Frequency Drive (AFD) and the efforts to protect both the AFD and incoming power.

When connecting an AFD to a system, there are 3 separate connections that are made: incoming power, motor wiring and control wiring. This lesson deals with the terminology concerning the first of these three, incoming power. Here is the basics outline for this lesson.

AFD Power Input Terminology

1. Protecting the AFD
 - a. Switching on the Input
 - b. Surge/Sag
 - c. Transients – Spikes
 - d. Phase Balancing
 - e. Single Phase
 - f. Fuses, connectors and voltages
2. Protecting the Supply Line
 - a. Radio Frequency Interference (RFI)
 - b. Harmonics, IEEE 519
 - c. Managing Harmonic Distortion



Incoming AC Power



- L1, L2 and L3 for modern label
- R, S and T older designations
- Terminals 91, 92 and 93 for Danfoss

This lesson covers the terminology involved in connecting a Adjustable Frequency Drive (AFD) to incoming AC power. The terminals used to connect incoming power to the AFD are labeled L1, L2 and L3. Older designations label these as R, S and T. In the drive shown above both labels are shown, along with the terminal numbers for Danfoss which are 91, 92 and 93.

When connecting the drive to incoming power the current needed by the drive is always the primary consideration. It is important that the transformer, wires and fuses can handle the full load amps of the drive. It is also very important that local electric codes are followed. The National Electric Code (NEC) requires branch protection and UL certification requires fuses be used with the drive.

There are 2 major concerns when wiring incoming power to the drive. The first is that the AFD must be protected from any variants from the incoming supply line. The second is that the supply line must also be protected from “noise” made by the drive. Anytime diodes or SCRs are used to change AC into DC, switching occurs creating a non-linear load. This non-linear load can have an adverse effect (noise) on the supply power going to the AFD. In the notes that follow this “noise” is explained in more detail.

1) Protecting the AFD

Danfoss

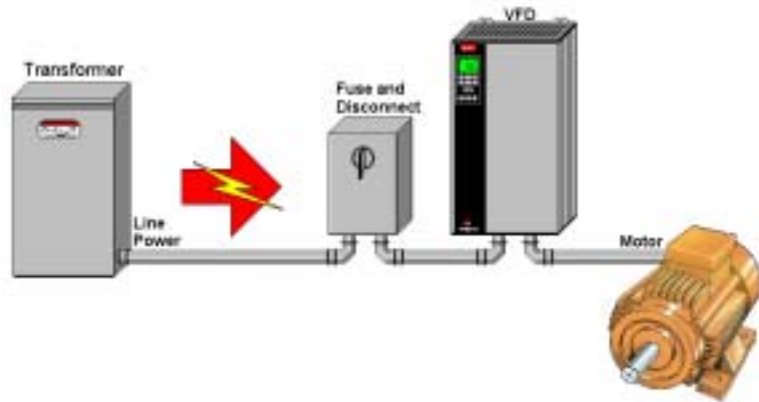

- Numerous Stray Voltages and power changes from incoming power can effect the AFD.

The first section covers the protection of the AFD from the changes in incoming power. The first item covered is the switching of power coming into the drive. There can also be Surges and Sags in the incoming AC power. If these surges are too high, or the sags are too low, the AFD shuts down for its own protection. There must also be protection against transients or spikes in the incoming power. Another item to be covered is a Phase Imbalance between the 3 phases of power coming into the drive. The last item to be covered are Fuses, connectors and different voltages which might be encountered.

a) Switching on the Input

Danfoss

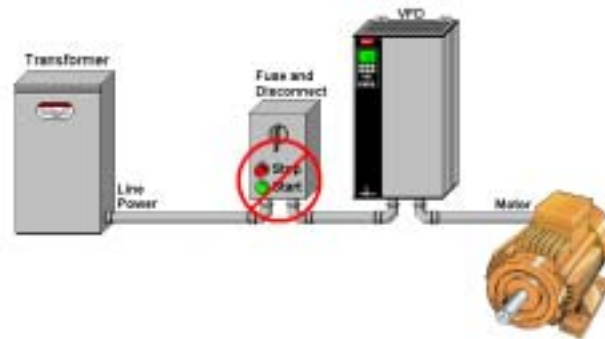

- Maximum switching on input is 2 times per minute
- Soft Charge circuit heats up with excessive starts, and charging and discharging of the capacitors needs to be limited.

Rapidly and repeatedly switching power on the input to the AFD can have a very negative effect on the drive. The power going into the drive requires the capacitors to be charged, which requires power to travel through a soft charge circuit. If this is started repeatedly, the current going through the current limiting resistors can cause the resistors to overheat and blow fuses on the soft charge circuit, disabling the drive for its own protection.

The stress on the capacitors powering up during the ON cycle, then discharging during the OFF cycle can also shorten the life of the capacitors and also the life of the drive. For these reasons it is important that the drive be limited to just 2 starts per minute. If the drive needs to start and stop its motor repeatedly, it is best to always use the drive's control circuitry.

b) Surge and Sag

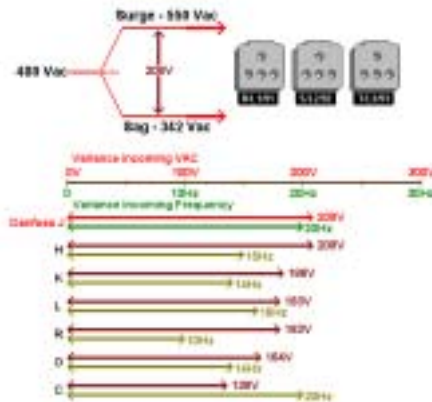

- Surge is an incoming voltage above its expected level
- Sag is an incoming voltage below its expected level
- Frequency shifts between 45Hz to 65Hz, can also occur.

It is important that an AFD be able to operate even though the voltage is changing coming into the drive. With an increase in voltage, a surge, the AFD continues to run its load until an upper limit is reached. To protect itself, once the voltage exceeds this limit, the drive trips into an alarm condition. In the example above, 7 manufacturers are shown in the tolerance range for changes in the incoming voltages. Danfoss has one of the widest ranges concerning incoming voltage shifts. Notice that a 480Vac drive has a surge trip point of 550Vac.

A drop in voltage, a sag, is far more common, particularly in the summer. In the example above, using a 480Vac drive, the sag trip point is 342Vac. As the voltage drops from 480Vac down, the AFD starts to drop its maximum output down from 100%. It continues to operate but at a lower level during these "Brown-Out" conditions. Once the voltage drops below 342Vac, the AFD trips to protect itself.

If there is a slight frequency shift away from 60Hz in North America, or 50Hz in the rest of the world, the AFD must continue to operate. In both cases, if the voltage swings or frequency shifts the wider the drive can handle the fewer nuisance shut-downs. In both cases, no one exceeds Danfoss in the range of voltage or frequency as indicated in the example above.

c) Transients and Spikes

Danfoss

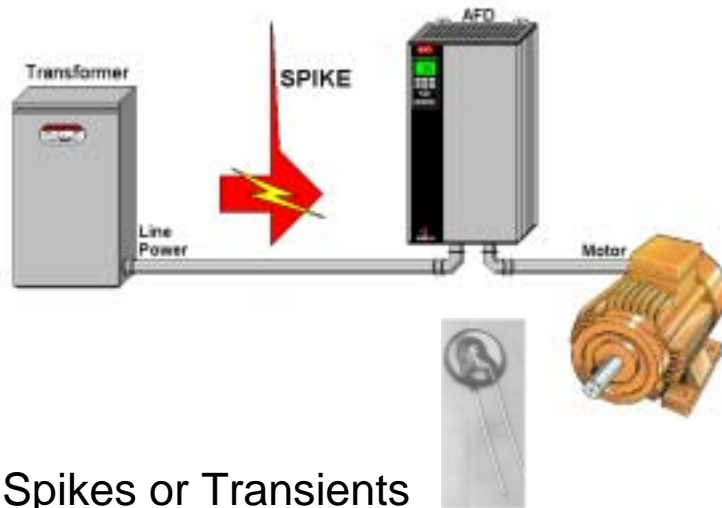

- Spikes or Transients
- Metal Oxide Varistors (MOV)

Another problem that might be encountered with incoming power is spikes or transients of voltage, which occur for a very short amount of time. These spikes may be caused by heavy loads in the main supply being switched ON then OFF, or even by lightning strikes. An AFD must have the capacity to handle these spikes in the same way that personal computers need surge protection.

Some manufacturers, such as Danfoss, use a fast acting Metal Oxide Varistor (MOV), zener diodes and oversized DC bus capacitors to provide protection against high potential spikes. The MOV which looks like a small capacitor is pictured above. When the voltage exceeds 2.3 times the expected incoming voltage for 1.3 milliseconds, the MOV shorts, protecting the internal parts of the drive. Danfoss places 4 of these MOVs in its drive, one on each of the 3 inputs and one attached to the DC Link. Danfoss drives are designed and built to meet a tough German specification for surge suppression (VDE 0160).

d) Phase Imbalance

Danfoss

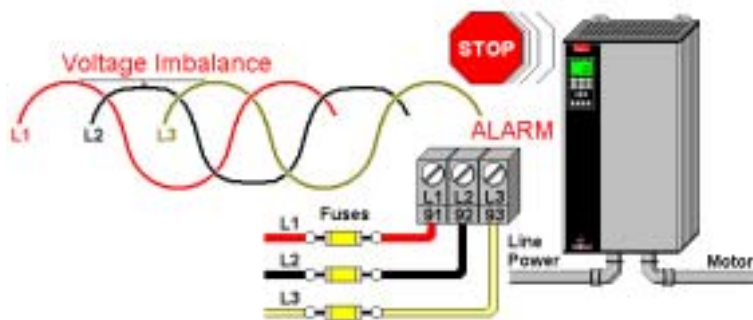

- Voltage Imbalance on one of the Phases causes excessive stress on filter capacitors, so the AFD shuts down and sends out an alarm.
- The closer to maximum load of the AFD the more sensitive it becomes to an incoming voltage imbalance.

Another problem with incoming power can be a phase imbalance between the 3 phases. A voltage imbalance on one of the phases causes excessive stress on filter capacitors. When the AFD sees an amount beyond 2%, the AFD shuts down and alarms the operator letting him know that there is a problem with the incoming power. This 2% imbalance becomes more crucial as the drive approaches its maximum load. The closer to maximum load the more sensitive the drive becomes to an incoming voltage imbalance.

There are some parts of the world that almost always have a phase imbalance of at least 2% or more. Some AFD manufactures, such as Danfoss, allow the turning off of the phase imbalance protection for those locations. It must be remembered with a large constant phase imbalance, the expected life of the AFD is reduced.

e) Single Phase Input

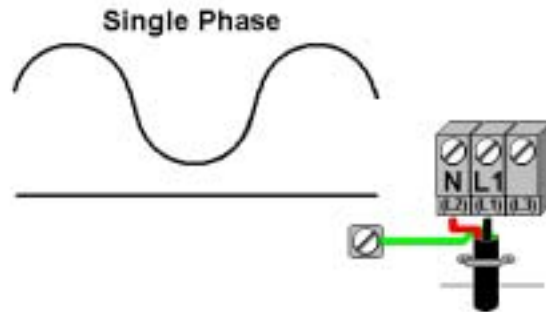

- Some small AFDs are designed for single phase
- It is NOT recommended to place single phase on a 3-phase only - AFD
- Reduces life of filtering capacitors

Single Phase into the drive is possible with some smaller size drives, usually 3Hp and under. Notice in the picture above single phase terminals are labeled N and L1. While possible to use single phase input on a 3-phase drive when properly engineered, it is NOT officially recommended or supported by Danfoss. Performance and long term reliability problems may result. One of the biggest concerns with single-phase input is the effect it has on the filtering capacitors.

f) Fuses, Connectors and Voltages

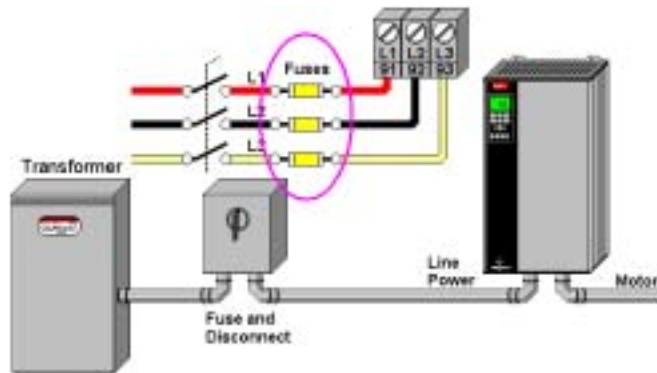

- Fuses
- No Power factor correction capacitors

Fuses must be placed between the AFD and the transformer. Instruction manuals for each size of AFD identifies the correct type and size of fuses needed for the installation. According to UL, fuses must be used with an AFD because of the quickness of fuse protection, when compared with circuit breakers. It should be noted that fuses do NOT completely protect the drive but do reduce the damage during a short circuit or other problem.

On a retrofit, if power factor correction capacitors are found with the motor, and the customer wants them with the new AFD installation, they must be placed between the transformer and the AFD and never between the AFD and the motor.

f) Fuses, Connectors and Voltages

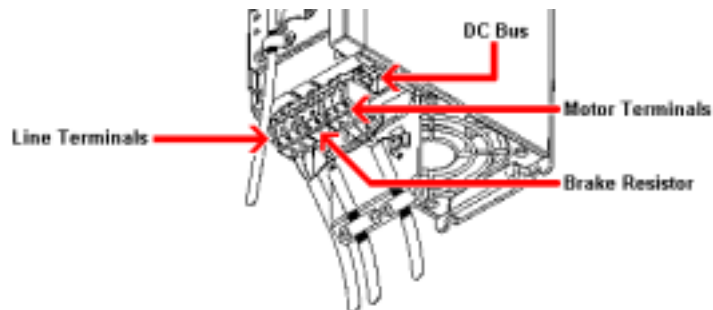

- Quick Connections are needed for quick replacement.
- Cable clamps are very helpful, but must also have a quick release.

A note in passing is that most drives need quick release connectors to remove power, motor and control wiring. In the diagram above plugs are used to remove the incoming power. This is very important particularly in the industrial market where lost time is measured in the thousands of dollars per minute.

Cable clamps are another helpful addition to drives. These clamps relieve the tension from the wire connectors. Incidental pulling of wires on those drives that do not have clamps can have a very adverse effect on the drives.

f) Fuses, Connectors and Voltages

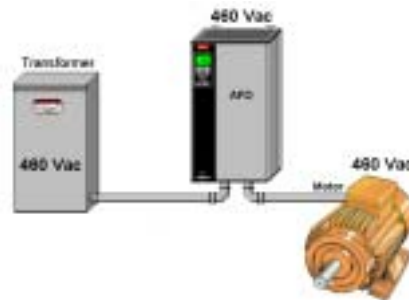

- 120Vac used by very small motors in North America
- 230Vac used by small motors
- 380Vac used by most motors in Europe
- 460Vac used by most motors in USA
- 575Vac used by most motors in Canada
- 690Vac used by some motors in Germany

There are a number of voltages that may be used by AFDs. In North America there is a growing demand for small portable drives that use 120Vac. Many small motors worldwide use 230Vac. In Europe, there are many motors that use 380Vac, but the current standard is 400Vac. On larger motors throughout the world, but particularly in North America, 460Vac is used. Canada and some places in South Africa and in the Northeast and Southeast parts of the USA use 575Vac. Germany has just recently allowed the use of 690Vac. It is important that AFD manufacturers can handle a variety of voltage ranges.

2) Protecting the Supply Line

Danfoss

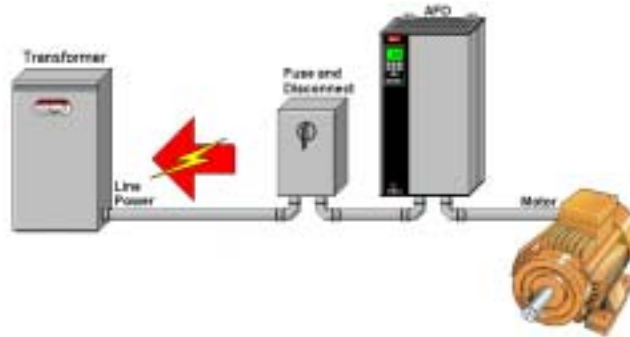

- Voltage and current distortions caused by the AFD can effect in-coming power.
- High Noise above 450kHz is called Radio Frequency Interference (RFI) and low noise below 3kHz is called Harmonics.

Not only must the AFD be protected from the incoming power, it is also important that the main power supply and all other equipment attached to this transformer be protected from the noise generated by the AFD. All AFDs generate noise. Noise, as **voltage distortion** in the supply line, can cause sensitive equipment such as computers and PLC to malfunction. Noise as **current distortion** in the transformer causes heat in the transformer and associated wiring. This noise can be described as 2 different types:

- 1) Radio Frequency Interference (RFI) and
- 2) Harmonics.

RFI is considered as 450kHz and higher traveling through the wires and also being radiated through the air. Many of these problems can be corrected by using RFI filters in the drives and shielded (screened) cable. RFI is a major concern when using drives in Europe.

Harmonics are the noise at low frequencies, less than 3kHz which are only generated through the wires and never radiated through the air. Engineers in North America seem to be more concerned with harmonics. Both of these and managing harmonics are covered in some detail on the pages that follow.

a) Radio Frequency Interference (RFI)

- Noise RFI
- CE EN 55011
- 1A Filter
- 1B Filter
- Grounded Delta

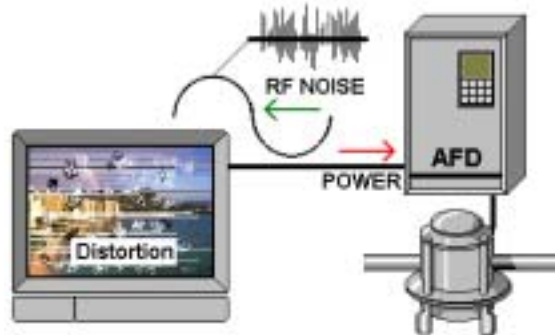

What is RFI? A child likes to watch the TV on Saturday morning, which happened to be his mother's cleaning day. She plugs the vacuum cleaner into the same power outlet that the TV is connected. When she turns the vacuum on, because of its non-linear load, distortion or "snow" appears on the TV. That is RFI or noise. Now with a TV there is little problems, but with sensitive equipment such as transmitters, PLCs and computers there could be real problems.

Since this is a major concern for Europe, CE has taken steps to measure and limit RFI in industrial, scientific and medical area covered in EN 55011. Under these guidelines, Class 1A filters are used for industrial areas and Class 1B filters, which filters more, are used for residential. There is a specific product standard which covers AFDs known as EN 61800-3.

Special RFI filters either 1A or 1B can be ordered with most drives. If filters are installed on a drive and in those applications where power to the drive is coming through a delta secondary transformer there are precautions that should be taken. On these systems which are described as "grounded delta" transformers, it is best to disconnect the ground connection of the drive's RFI Filter which is done by using a switch or a jumper.

b) Harmonic Distortion

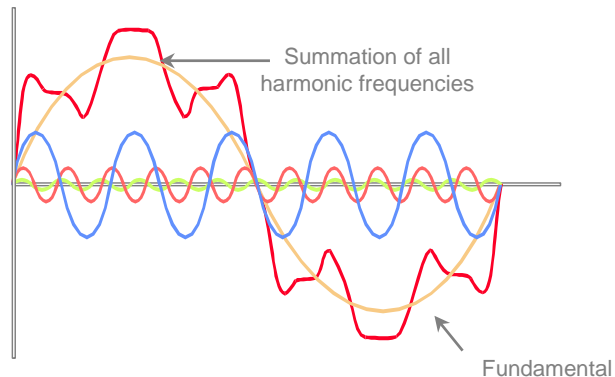

Multiples, mainly the 5th and the 7th harmonics of the fundamental sine wave (60 Hz), caused by the switching current flow through the AFD's input rectifiers, causes interference in the incoming power.

Harmonic distortion has been a hot topic in North America with the ever increasing use of equipment incorporating rectifiers and similar switching devices on the input. This noise is low frequencies that appear on wires coming from the supply transformer.

In the example above, notice the orange fundamental sine wave which comes from main power supply. In a 6-pulse drive, one that has 6 diodes or SCRs rectifying the AC power to DC, the 5th harmonic (300Hz) is quite large as seen in the blue sine wave. The 7th harmonic (420Hz) is also quite large as seen in the pink sine wave. The summation of all of these sine waves is shown in red, and you can see the distortion that exists on the power supply. The harmonic distortion is related to the number of diodes used to rectify AC to DC. As the number of harmonics increases, the lower their amplitude, which means less problems. The 5th and 7th harmonics have a much greater amplitude than the 11th and 13th which have a greater amplitude than the 17th and 19th. The reduction of the 5th 7th and 11th harmonic signals are the greatest concern.

b) Harmonic Distortion

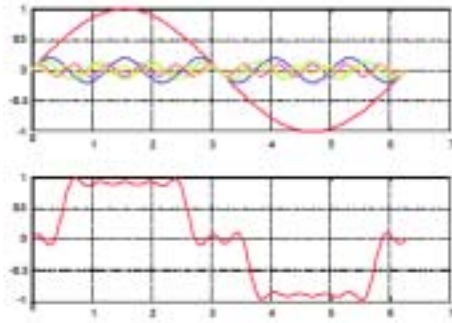

- Harmonic Current Distortion increases the RMS current and can result in overheating of the supply transformer and cables.
- Harmonic Voltage Distortion can interfere with other equipment attached to the same line.
- Total Harmonic Distortion (THD) at the point of common coupling is discussed in IEEE 5-19.

Harmonic current distortion causes heat and this has an adverse effect on the supply transformer and cables. Based on the impedance of the supply line and transformer, current distortion can cause harmonic voltage distortion, which can interfere with other equipment attached to the same supply transformer.

Harmonics is discussed by a North American standard which is IEEE 5-19. This harmonic distortion is seen as a system measurement known as the Total Harmonic Distortion or THD which is measured at a point of common coupling, PCC, usual where the electric meter is placed. This standard indicates limits of allowable THD distortion of 3% 5% and 10% dependant on the sensitivity of the application. IEEE 5-19 is a system standard not an equipment standard as some claim. There are times where the THD is high but with the addition of other loads the THD is dropped because additional rectifiers can cancel out some of the harmonic frequencies. In the pages that follow a procedure for harmonic remedies is reviewed



c) Managing Harmonic Distortion

- Analyze system to determine whether harmonic distortion is an issue.
- If it is an issue:
 - 1) Redistribute Sensitive Loads
 - 2) Rewire as Virtual 12 Pulse
 - 3) Add Remedial Hardware
 - Line Reactors
 - Filters
 - Isolation Transformers

If the transformer supplying power to the AFDs and other equipment is operating hot or if other equipment has noise problems here is a way to manage harmonic distortion. The first step is to analyze the THD harmonic distortion at the point of common coupling and determine if it is a problem. If it is a problem then there are some remedies.

To rectify problems with harmonic noise, one way is to move the equipment that is sensitive to noise on to a different power supply. Another way to reduce harmonic noise is to use one 30° phase shift transformer to supply 2 sets of AFDs. The last remedy is to purchase additional equipment, such as line reactors, filters or isolation transformers. These remedies are explored in detail on the following pages.

c) Managing Harmonic Distortion Remedial Hardware

Danfoss

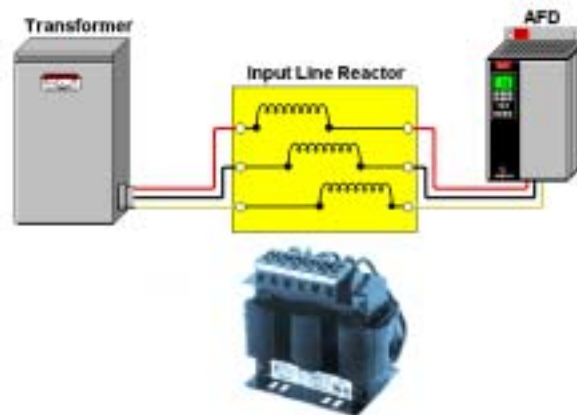

- Input Line Reactor

One of the most common remedies used by many drive manufacturers is to place an input line reactor (between 3% to 5%) between the drive and the power supply. This does reduce the harmonic noise, but it also reduces the voltage going to the drive. This reduced voltage might be a problem when the drive is used at maximum load and maximum speed. The motor can become voltage starved. This might require the AFD to be a size larger to avoid nuisance tripping.

c) Managing Harmonic Distortion Remedial Hardware

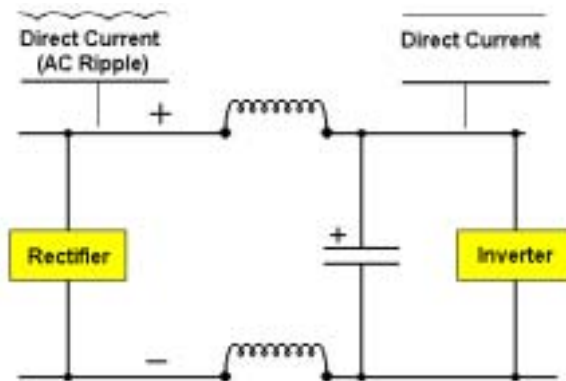

- DC Inductors

Another way to reduce harmonic noise is to use DC inductors or chokes built in the drive. These eliminate some of the noise, usually about 40%. This method is what Danfoss uses, building DC inductors into all of its drives. These DC inductors are expensive which has caused most AFD manufacturers to offer them as options.

c) Managing Harmonic Distortion Remedial Hardware



- Isolation Transformers
- Expensive option

Another option to stop harmonic noise is to place an isolation transformer between the drive and sensitive equipment. Most of the noise if engineered correctly stops at the isolation transformer. This can be a very expensive option. In the past, many drive manufacturers required isolation transformers to prevent ground faults and protect against uneven phase to ground voltages.

c) Managing Harmonic Distortion Remedial Hardware

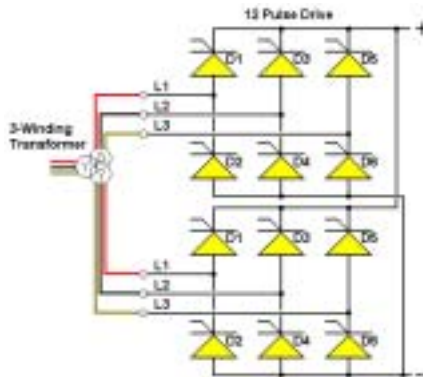

- 12 Pulse Drive

- Cancels 5th and 7th harmonics

- Works with much smaller 11th and 13th harmonics

- Must have 30° phase shift transformer

- Works best with perfect balance between phases

Another option is to produce AFDs with 12 diodes in the rectifier section, known as a 12-pulse drive. This theoretically cancels the 5th and 7th harmonics and only allows the much smaller 11th and 13th harmonics and higher to interfere. One manufacturer has aggressively pursued this option, producing 12-pulse drives, and 18-pulse drives. This manufacturer then uses drive specifications to eliminate competitors.

In order to make the 12-pulse option work correctly, a 30° phase shift transformer must be included. If both sets of 6-pulse diodes are attached to the same transformer output, it makes the drive no different than a 6-pulse drive and its harmonic limitations.

To make the noise reducing features of a 12-pulse drive work best, the 3-phase inputs from the transformer should be perfectly balanced. In real life, there is almost always a phase imbalance between the 3 inputs. As the imbalance increases, harmonic distortion increases.

c) Managing Harmonic Distortion Rewire

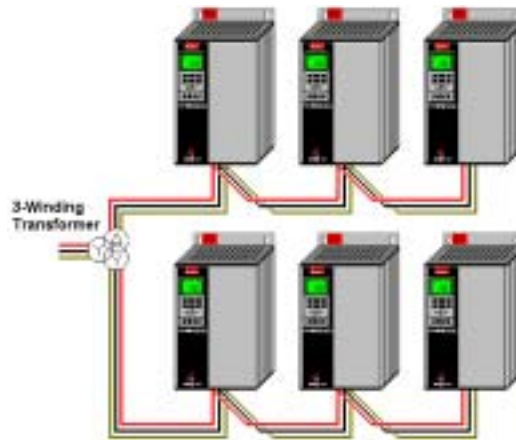

- Virtual (Quasi) 12-Pulse
One phase shift transformer for multiple drives

One way to avoid the more expensive 12-pulse drives is to wire the drives in a virtual or quasi 12-pulse configuration. Here a large 30° phase shift transformer is used to power 2 sets of AFDs, one from the standard part of the transformer and the other from the 30° phase shift part. This allows the use of the much less expensive 6-pulse drives with the harmonic cancellation advantages of the 12-pulse.

c) Managing Harmonic Distortion Remedial Hardware

Danfoss

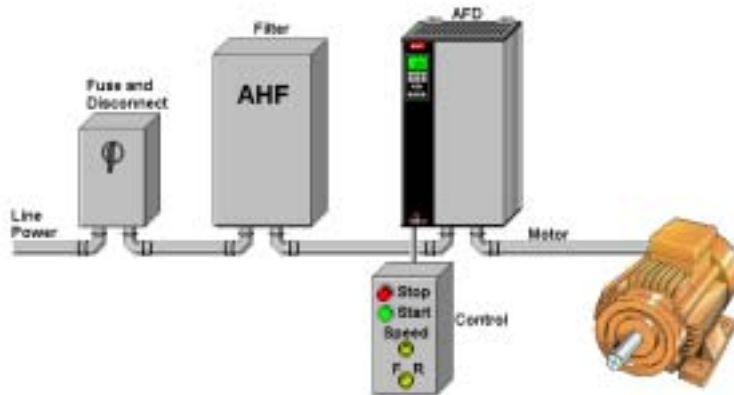

- Advanced Harmonic Filters (AHF)
AHF 005 & AHF 010 are designed for Danfoss AFDs.
AHF filter is placed between incoming power and the AFD.

Another option is to use a harmonic filter as pictured above. This device is mounted between the drive and incoming power and it reduces harmonic noise problems. These filters can be passive or active. The one pictured above is a passive filter specifically designed to work with Danfoss drives and their DC inductors.

Active filters have a logic controller that monitors the incoming power. It then calculates the necessary counter signals to eliminate the harmonic distortion. These active filters are more expensive.

c) Managing Harmonic Distortion Remedial Hardware

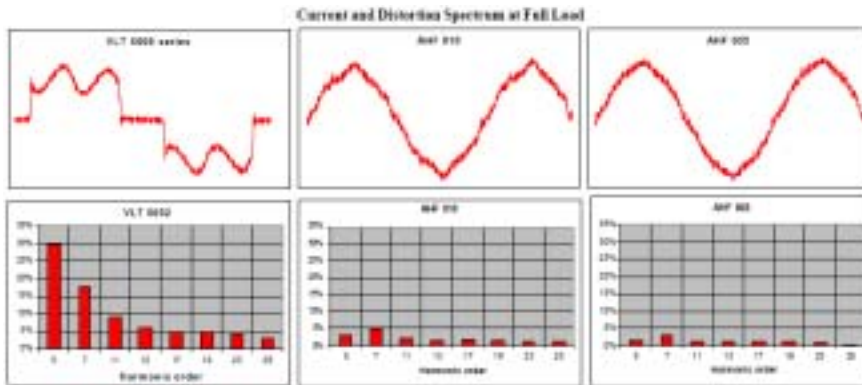

- **AHF Filters**

By connecting the AHF 005 or AHF 010 in front of the AFD. The harmonic current distortion generated back to the mains is reduced to a minimum.

In the diagrams above the bar chart to the left shows the amounts of current distortion on a 6-pulse drive that has DC inductors. When the AHF filters are placed upstream from the AFD, notice in the middle chart and the chart on the right that the harmonic levels are very small. Another advantage that the filters have over a 12-pulse AFD is there is only a slight increase in harmonics on the power when there is a phase imbalance.

c) Managing Harmonic Distortion

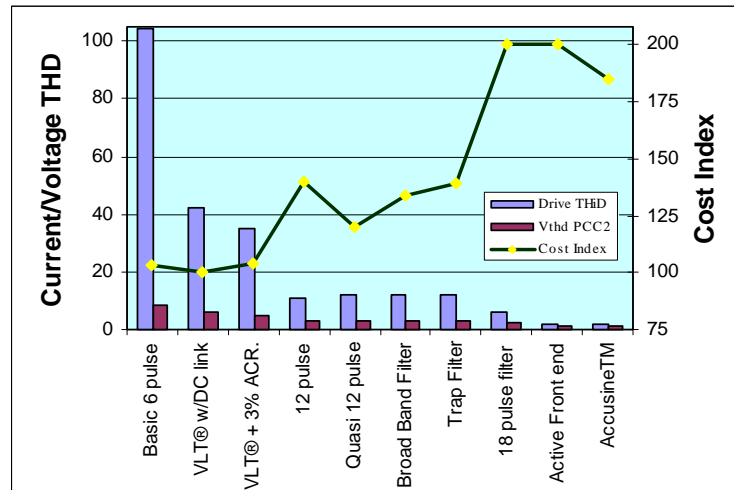

The Law of Diminishing Returns

Here is a chart showing the reduction of harmonics and the cost of each remedy. The blue bars show the THD on the supply line. Notice that a standard 6-pulse AFD has a very large harmonics level. The next remedy, 6-pulse with DC inductors, removes a great deal of harmonics. The index on the right uses this remedy as the 100% cost level. The next remedy, with 3% line reactor reduces the harmonics slightly and is slightly more expensive. The next remedy, 12-pulse reduces the harmonics significantly but the cost has risen by 40%. The next remedy, quasi 12-pulse has about the same noise level as a 12-pulse drive but only adds 22% cost.

The next remedies use passive filters, the broad band filter and the harmonic trap. Broad band filters as the name implies covers a range of harmonic frequencies. The harmonic trap is designed for a specific harmonic frequency, usually the 5th. The cost jumps significantly when the 18-pulse remedy is used, with only some reduction in the harmonic level. The new AHF filter is not shown on this diagram.

This completes this lesson.

There are Review Questions in the Post-Test section.