

Post -Test

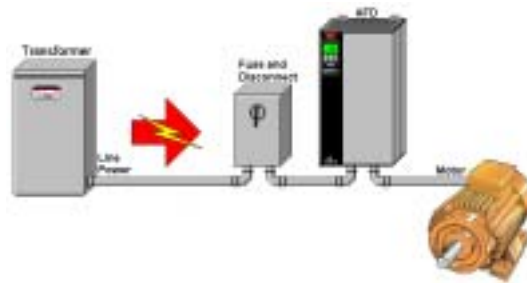

Multiple Choice

1. Which of the following is NOT a major concern when protecting the AFD from the incoming power?
 - A. Voltage Surge
 - B. Spikes
 - C. Phase Loss
 - D. Harmonics
 - E. Voltage Sag

2. The power coming into the AFD should be limited in cycling to how many power-ups per minute?
 - A) A maximum of 1 power-up per minute
 - B) A maximum of 2 power-ups per minute
 - C) A maximum of 5 power-ups per minute
 - D) A maximum of 10 power-ups per minute
 - E) Unlimited – this is no potential problem with cycling power on the input.

- 3) The main function of a MOV (Metal Oxide Varistor) located on the power wires going to the rectifiers inside the AFD is which of the following:
 - A) Protects the AFD from spikes on the incoming power.
 - B) Protects the transformer from spikes developed by the AFD.
 - C) Associated with the elimination of Radio Frequency Interference (RFI)
 - D) Associated with the elimination of Harmonics.
 - E) Both C and D are correct.

Post-Test



- 4) As the AFD gets closer to its maximum load, which of the following is true, concerning the imbalance on incoming power.
- A) The closer to maximum load, the more sensitive the AFD is to current imbalance.
 - B) The closer to maximum load, the less sensitive the AFD is to current imbalance.
 - C) The closer to maximum load, the more sensitive the AFD is to voltage imbalance.
 - D) The closer to maximum load, the less sensitive the AFD is to voltage imbalance.
 - E) None of the above are true.
- 5) To be UL listed, an AFD must have which of the following on the incoming power?
- A) Input line reactor.
 - B) Circuit breakers
 - C) Fuses
 - D) Disconnect
 - E) All of the above are required for UL listing.

6) Noise produced by the AFD going back into incoming power is defined as 2 types, Harmonics and Radio Frequency Interference (RFI). Which of the following is the best description for these 2 types of noise?

- A) Harmonics = or < 3kHz and RFI = or > 450kHz.
- B) Harmonics = or < 49kHz and RFI = or > 50kHz.
- C) RFI = or < 3kHz and Harmonics = or > 450kHz.
- D) RFI = or < 49kHz and Harmonics = or > 50kHz.
- E) These 2 names are interchangeable meaning the same thing.

RFI is most commonly used in Europe while Harmonics is commonly used in North America.

7) The engineering recommendation, IEEE 519 is always identified or mentioned when talking about which of the following:

- A) Radio Frequency Interference (RFI)
- B) Harmonics
- C) Surge/Sag Protection
- D) Transient Protection
- E) Nuisance trips

Pre-Test

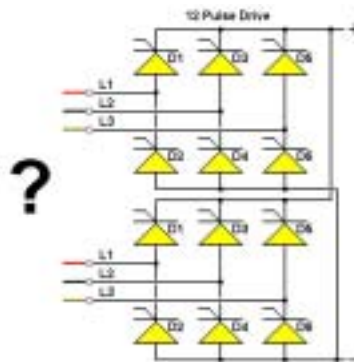

- 8) To make a 12-pulse AFD work correctly, which of the following is required for proper and the best in operation?
- A) A 30° Phase Shift Transformer
 - B) 5% Input Line Reactor
 - C) Perfect balance between the 3 phases on the input.
 - D) Both A and C but not B
 - E) All 3 answers, A, B and C.
- 9) When ordering RFI filters for a AFD, 2 classes of RFI Filters are commonly identified, according to EN 55011. They are which of the following:
- A) Class 1 for residential and Class 2 for industrial.
 - B) Class 1.1 for industrial and Class 1.2 for residential.
 - C) Class X for residential and Class Y for industrial.
 - D) Class A for residential and Class B for industrial.
 - E) Class 1A for industrial and Class 1B for residential.
- 10) When connecting an AFD, which has a built-in RFI Filter, to incoming power, it is discovered that incoming power uses a “grounded delta” on the secondary of the transformer. When the AFD is stopped, it trips in over-voltage. What must be done to the AFD to avoid these nuisance trips?
- A) Change incoming power leads. Move L1 to L2 and L2 to L1.
 - B) Change incoming power leads. Move L2 to L3 and L3 to L2.
 - C) Clip the MOV from the power card on the L3 input.
 - D) Change the incoming power parameter to indicate there is a grounded-delta input.
 - E) Switch RFI to OFF by using the switch or jumper.

Post-Test



Answers

- 1) D. Harmonics
- 2) B. A maximum of 2 power-ups per minute
- 3) A. Protects the AFD from spikes on the incoming power
- 4) C. Closer to max load, the more sensitive to voltage imbalance
- 5) C. Fuses
- 6) A. Harmonics = or < 3kHz; RFI = or > 450kHz
- 7) B. Harmonics
- 8) D. Both A and C but not B
- 9) E. Class 1A for industrial and Class 1B for residential
- 10) E. Switch RFI to OFF by using the switch or jumper.

Objectives:

1. Student is able to correctly identify 5 concerns of incoming power in protecting the AFD.
2. Student is able to correctly identify such terms as surge, sag, phase loss, spikes/transients, MOV, input switching, soft-charge circuit and single-phase.
3. Student is able to correctly identify the 2 concerns of the AFD noise affecting the power supply.
4. Student is able to briefly describe the following terms: RFI, harmonics, voltage distortion, current distortion, THD and IEEE 519.
5. Student is able to describe possible measures used to manage harmonic interference, including such terms as 6-pulse, 12-pulse, quasi 12-pulse, line reactors and isolation transformers.

If you have any comments or questions, please contact:

Mark Peterson

Training Manager - Industrial

Danfoss Drives

4401 N. Bell School Rd

Loves Park, Illinois 61111 USA

phone: (815) 639-8721 or (800) 432-6367

fax: (815) 639-8987 or (815) 639-8002

Email: MarkPeterson@Danfoss.com