

E2 Long Pin

Technical specifications

- Can be configured as
 - 6-pack
 - Long pin (molded/fixed pin configuration)
- Dimensions:
 - Size: 45×107.5 mm
 - Pitch: 3.81 mm
- Up to 690 V line voltage
- Up to 10 kW

E2 Long PIN

Collector Emitter Voltage V_{CE}	DC Collector Current I_C @ $T_C = 80^\circ C$	6-pack
600 V	10 A	DP10D600 * 1018xx
	15 A	DP15D600 * 1018xx
	20 A	DP20D600 101801
	30 A	DP30D600 101802
	50 A	DP50D600 101803
1200 V	10 A	DP10D1200 101804
	15 A	DP15D1200 101805
	25 A	DP25D1200 101806
	50 A	DP50D1200 101807
1700 V	50A	DP50D1700 101800

* Types under development. Custom circuits and configurations on request.

Outline

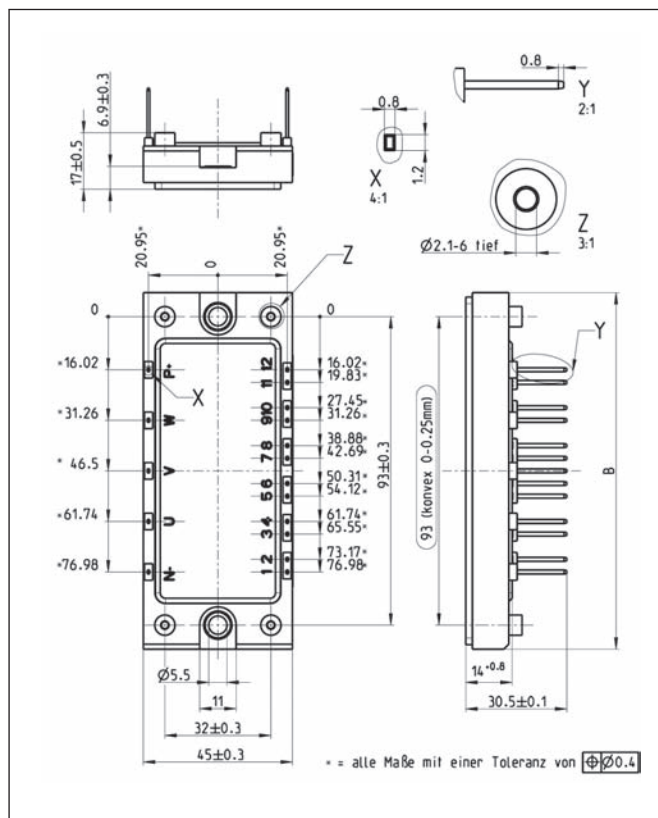

Circuit configuration

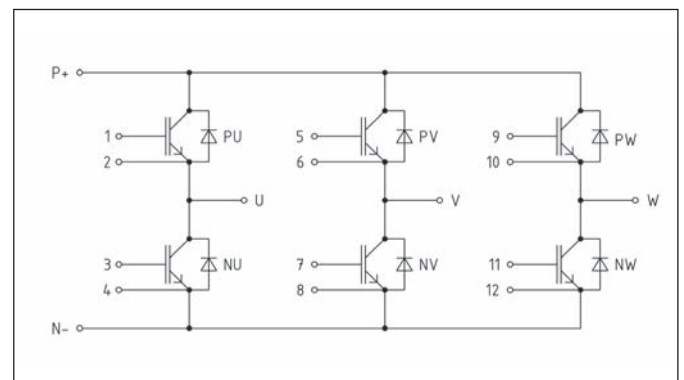

Danfoss Silicon Power GmbH • Heinrich-Hertz-Straße 2 • 24837 Schleswig • Germany

Tel.: +49 4621 9512-0 • Fax: +49 4621 9512-310 • E-mail: dsp-info@danfoss.com • <http://siliconpower.danfoss.com>

Danfoss can accept no responsibility for possible errors in catalogues, brochures and other printed material. Danfoss reserves the right to alter its products without notice. This also applies to products already on order provided that such alterations can be made without consequential changes being necessary in specifications already agreed. All trademarks in this material are property of the respective companies. Danfoss and the Danfoss logotype are trademarks of Danfoss A/S. All rights reserved.