

Whitepaper

Harmonic Distortion of the AC Power Line

Introduction

Adjustable frequency drives have become the standard method of control for heating, ventilating and air conditioning (HVAC) systems due to precise control and very significant energy savings. They have been used in industrial applications for years for precision process control.

Commercial HVAC systems are often quite different from industrial applications. In most HVAC installations, the adjustable frequency drive shares the AC power supply with sensitive electronic equipment such as computers, telecommunications networks, lighting and clocks. When the HVAC system is in an airport, hospital or research facility,

the amount of sensitive equipment increases dramatically. A possible concern in such environments can be harmonic distortion on the AC power line generated by the adjustable frequency drive and other electrical equipment. Harmonic distortion is not a concern in most industrial environments.

The following examines harmonic distortion of the AC power line, an aspect of electrical current generally called "noise." The causes and effects of such noise will be discussed, as well as remedies, and some considerations for selecting a drive to satisfy application requirements.

Causes of power line distortion

Most adjustable frequency drives operate by using a bridge rectifier to convert the incoming AC voltage to DC voltage (see figure 1). An inverter in the drive then converts the DC voltage into a precise output voltage and frequency to control the speed of the motor.

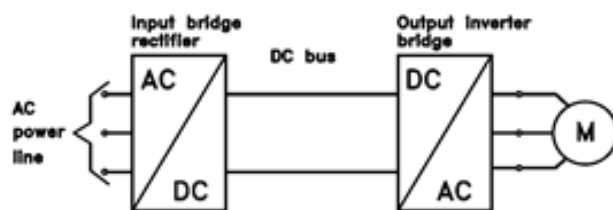

Figure 1: General block diagram of an adjustable frequency drive.

Drives today use a diode bridge rectifier to convert the AC line power into a fixed-voltage DC bus (see figure 2). A DC bus capacitor bank is then used to filter out the AC ripple.

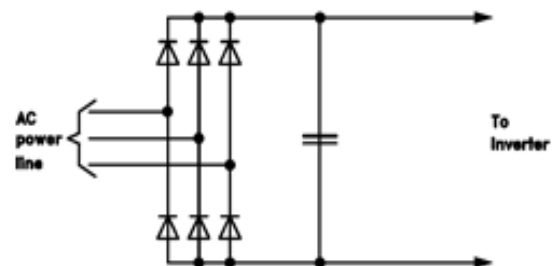

Figure 2: Diode bridge rectifier on a PWM drive.

While this results in a very efficient drive, it can cause disturbances on the AC power line due to the way the drive draws AC current. Current cannot flow from the rectifier into the DC bus until the input voltage is greater than the DC bus voltage. As shown in figure 3, this only happens for a very short period of time for each phase. This causes a non-sinusoidal current flow created by the input stage of the drive. In order to transfer the energy required by the motor in such a short period of time, the peak current must be high.

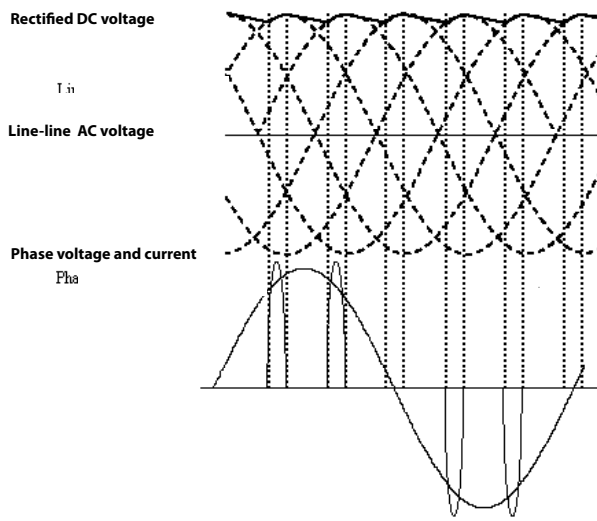

Figure 3. Input with high peak current.

The input current is non-sinusoidal. It consists of two discrete pulses per half-period. Because the current pulses are centered in the voltage period, the displacement power factor is almost one. The result is that such a current waveform has a high level of harmonic distortion.

Most modern electronic equipment use this type of bridge rectifier power supply. Computers, fax machines, copy machines, and electronic lighting ballasts all use switch mode power that draws current in a non-sinusoidal manner. Because the current is not proportional to the supplied voltage, such loads are called non-linear.

Measuring power line distortion

The degree of the voltage distortion varies with the impedance of the building's electrical power distribution system and the number and type of non-linear loads connected. In order to compare these two distortion levels, it is necessary to quantitatively describe the distortion. Harmonic analysis is used to provide this description. The level of voltage distortion that is acceptable depends on the sensitivity of the equipment installed in the building.

In harmonic analysis, any repetitive wave form can be described mathematically as a series of pure sine waves. These sine waves consist of a fundamental frequency and multiples of that frequency, called harmonics. There are two ways to express the results of this mathematical analysis.

The most detailed method describes the amplitude of each individual harmonic component, either in absolute units (such as volts) or as a percentage of the fundamental component. With this, it is possible to determine the source of harmonic distortion. For example, in a balanced electrical system, the only harmonics that can be generated by a symmetrical three phase load are those that are not multiples of 2 or 3 (the 5th, 7th, 11th, and similar harmonics). If a third harmonic is present in the system, it is likely the result of single phase loads or phase imbalances. Detailed analysis also helps in designing specific filters to solve harmonic distortion problems.

For a less detailed view, total harmonic distortion (THD) is often used. As a percentage, this single number is calculated by adding the square of each relative harmonic value and taking the square root, as shown in figure 4.

$$THD = \sqrt{\sum_{n=2}^{\infty} \left(\frac{H_n}{H_1}\right)^2} \cdot 100\%$$

Harmonic distortion limits

Because harmonic voltage distortions can affect the operation of other devices connected to the same power grid, various standards have been established to judge the severity of harmonic distortion. One of these is IEEE 519 by the American Institute of Electrical and Electronic Engineers. This standard recognizes the sensitivity of electrical equipment in a building as the limiting factor on how much voltage distortion is acceptable. IEEE 519 therefore provides limits for different types of buildings. As can be seen in figure 5, the limitation is more stringent in facilities likely to contain sensitive electronic equipment.

Application Class	THD (%)
Sensitive Applications <ul style="list-style-type: none"> Airports/Hospitals Telecommunication Facilities 	3%
General Applications <ul style="list-style-type: none"> Office Buildings/Schools 	5%
Dedicated Systems <ul style="list-style-type: none"> Factories 	10%

Figure 5. IEEE 519 standards for total harmonic voltage distortion.

Effects of power line distortion

On three phase systems, the actual current to an adjustable frequency drive flows in two pulses that are 60° apart. For line 1, one pulse occurs when the voltage difference between L1 and L2 is at maximum. A second pulse occurs when the voltage difference between L1 and L3 is at maximum. The actual input current to a typical drive, or other similar electronic equipment, is shown in figure 6. These short duration, high peak current pulses can cause a number of problems to the rest of the building’s electrical systems.

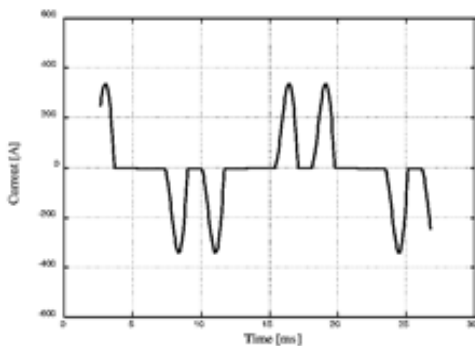

Figure 6. Input current to a basic adjustable frequency drive.

One concern relates to the power transformers that supply the drive. Transformers are designed to handle smooth, sinusoidal current. Short current pulses like the ones shown above cause additional heating in the transformer. If the transformer is not designed to safely accommodate such currents, it may overheat and fail. Without harmonic distortion protection, it may be necessary to increase the current carrying capacity of the transformer.

A second concern is interference with other equipment. The strength of the magnetic field that is built up around a wire is proportional to the pulse rate of current in the wire. These fast changing current pulses transmit a stronger electrical noise signal than a normal sinusoidal current. This can result in an audible hum in other equipment, unstable displays on monitors, unreliable data transmission, or interference with the operation of sensitive electronic equipment.

Thirdly, such current pulses cause a more widespread and, therefore, more critical problem. Because the current draw occurs in pulses, and because voltage equals current multiplied by system impedance, the voltage waveform will not be sinusoidal. It will be similar to the waveform shown in figure 7. This phenomenon is often referred to as “flat top-ping.”

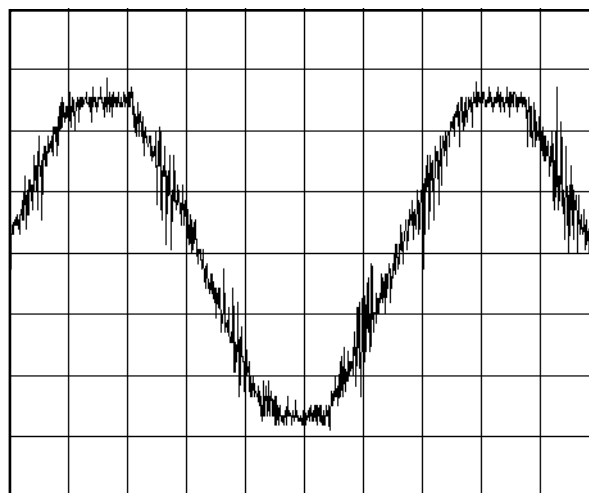

Figure 7. Typical phase-to-phase voltage distortion.

Remote lighting control systems, clock synchronization and other systems which rely on the building’s electrical power distribution to transmit information, may operate erratically due to clipping of the carrier current voltage peaks. The voltage regulators on emergency power generators may cause unstable generator operation as they attempt to compensate for the missing voltage peaks. Other equipment, which depend upon a “clean” source of power to operate reliably, may also be affected. Because this same voltage is used by all of the electrical equipment connected to the circuit, its effects can be quite wide spread. Therefore, this voltage distortion is a major concern.

Controlling harmonic distortion

When adjustable frequency drives are applied to HVAC systems, it is important to limit the harmonic voltage distortion that they can cause. When an industrial adjustable frequency drive is used in an HVAC application, this important caution is too frequently overlooked. As a result, the entire building’s electrical system may suffer.

The key to controlling harmonic distortion is limiting the current pulses. This is generally accomplished through the use of inductor coils, which may also be called reactors or chokes, on the input of the drive. The inductance of a coil creates a back electromotive force (emf), or voltage, as the current pulse passes through it. This reduces the rate of the current pulse.

In adjustable frequency drive testing, the rms input current for a drive without harmonic filtering was 107% of the fundamental current for a drive with harmonic filtering. These tests were made using a moderately high impedance power line. If the power line impedance is lower, the difference could approach 175%. This additional current could require an increase in the size of all devices supplying current to the drive: the wires, switch gear, and transformers.

The effects on a transformer for a drive without harmonic filtering is shown in figure 8. The solid line represents the transformer’s output kVA capacity for power delivered to the drive. The large harmonic content of the current drawn by the drive requires the transformer’s kVA rating to drop rapidly as the drive load increases. The dashed line represents the drive kVA demand. Because the total power factor of the drive is relatively low, the kVA demand rises rather quickly. Where these two lines cross represents the maximum drive load that the transformer can supply. As shown, the transformer can only be loaded to 44% of its nominal power for drives without harmonic filtering. This means that the transformer has to be almost twice its size.

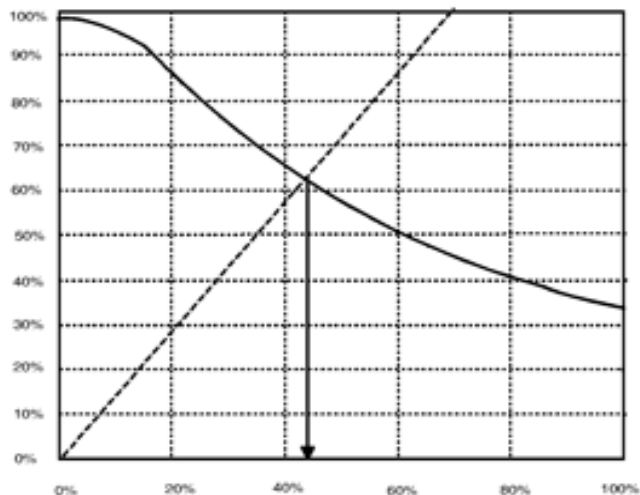

Figure 8: Distribution of linear load and drive load.

When DC link reactor is applied to the adjustable frequency drive for harmonic filtering, transformers can be loaded much more than what was possible before. Figure 9 shows that the transformer can be loaded up to 71% of its nominal power. The reduced harmonic current drawn by the drive causes the transformer’s kVA rating to reduce slowly as the drive load increases. Because the total power factor of the drive is relatively high, the kVA demand of the drive is close to the power delivered to the drive. This reduces the THD to 42% and is achieved without impacting the drive or motor performance.

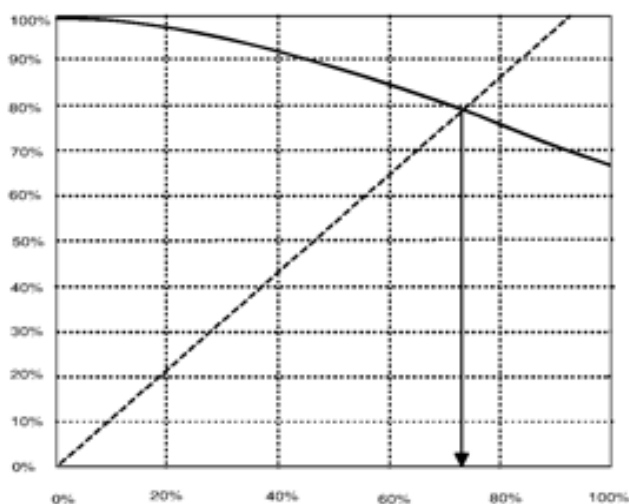

Figure 9. Maximum drive load on a transformer using DC reactors.

The input current for a drive with filtering in the DC bus is shown in figure 10. The larger input current pulses of a drive without input coils (from figure 6) are shown in gray. The improvement in the current draw is significant with greatly reduced harmonic distortion on the AC power line. This benefits the building's THD and increases transformer load.

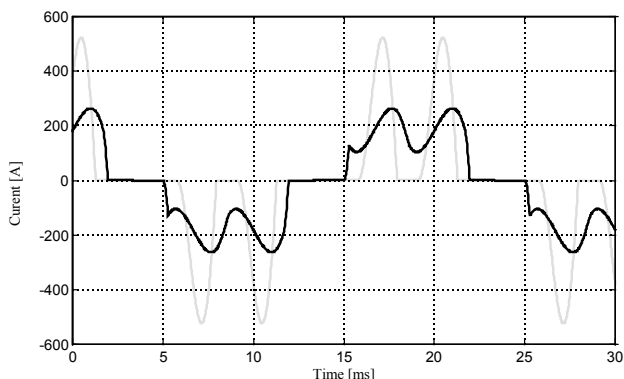

Figure 10. Input current to a drive with DC link reactors.

The graph in figure 11 shows the amplitude of each harmonic current and compares the harmonic current spectrum caused by a drive with and without harmonic filters.

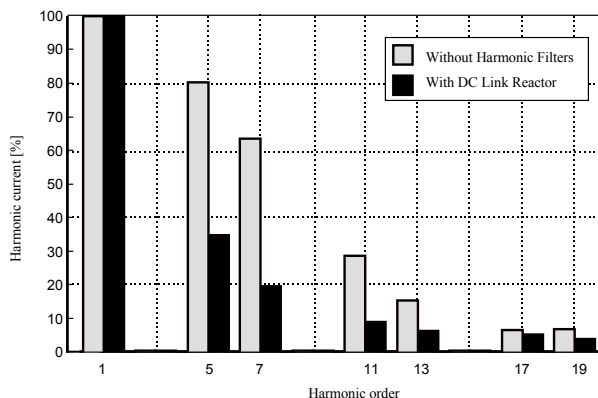

Figure 11. Comparison of the harmonic current spectrum.

The table below compares the total harmonic distortion and the true power factor measured in these tests.

	Drive without harmonic filtering	Drive with DC reactor
THD	107 %	42%
True power factor	0.68	0.91

The important concern is the voltage distortion caused by the current distortion. Figure 12 shows the voltage wave form that resulted when a drive with a DC link filter was connected to the same power line and load as the unfiltered drive. The voltage wave form lacks any significant flat topping. The contribution to harmonic distortion is greatly reduced.

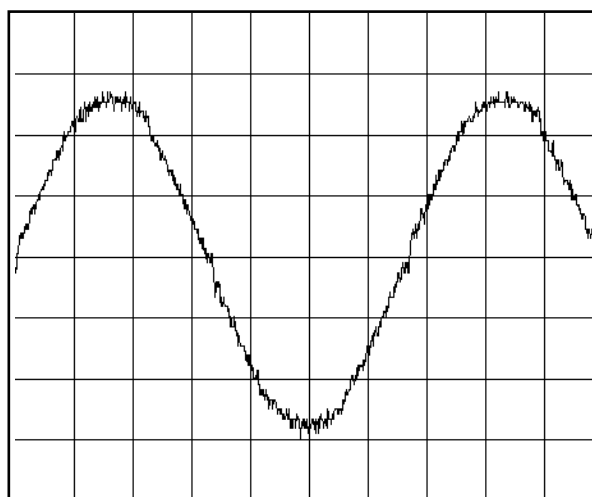

Figure 12. Input voltage to a drive with DC link filter.

The total harmonic voltage distortion for the drive in figure 8 was measured at 4%. This is unacceptable for critical applications. For the drive represented in figure 12 with DC reactors, THD was 2%. This meets even the most stringent IEEE standard. The true power factor increased from 0.68 for an unfiltered drive to 0.91 for a drive with DC reactors.

Placement of harmonic filters

There are two fundamental locations where harmonic reducing reactors are added to an adjustable frequency drive.

The method used in the VLT HVAC drives is shown in figure 13. Because the drive is designed specifically for HVAC applications, limiting harmonic distortion on the power line was part of the design criteria. As a result, the drive contains built-in filter reactors. Connected between the input rectifier and the DC bus capacitor, they are called DC link reactors.

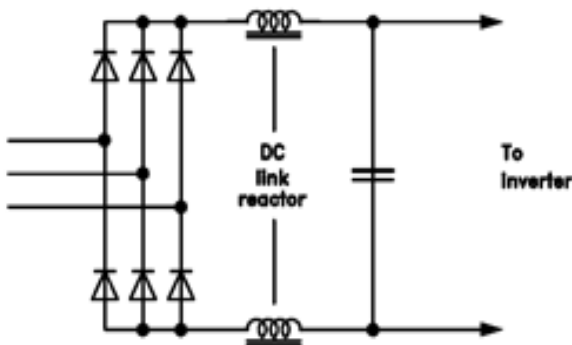

Figure 13. VLT HVAC Drive with built-in DC link reactors.

When an adjustable frequency drive lacks harmonic filtering, it may be necessary to add external filtering before use in HVAC applications. This is the purpose of the AC line reactors as shown in figure 14. The AC line reactors must be external to the drive and applied to all three input phases.

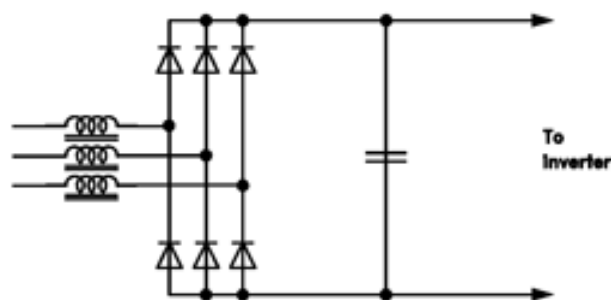

Figure 14. Conventional drive with optional AC line reactors added.

Comparison of DC link reactors and AC line reactors

Both DC link reactors and AC line reactors can significantly reduce AC power line voltage distortion.

It is important that the AC or DC reactors used are sized correctly to achieve the necessary harmonic performance. The rating of AC line reactors has to be approximately 50% larger than DC reactors for them to have the same performance. And AC line reactors generally need a separate enclosure with the additional wiring, installation and space required. The current passing through the AC line reactors generates electrical losses which were not anticipated in the original design of the drive. This voltage drop across the AC line reactor reduces the voltage available to the drive. When low line voltage problems are a concern, the addition of AC line reactors will make matters worse. A 5% AC line reactor causes a voltage drop of 2.5% in the DC circuit of the drive. This decreases the allowable voltage fluctuation on the AC power supply. The power the drive supplies to the motor also decreases. The output power is restricted to the current rating of the drive and cannot compensate for a drop in output voltage. The voltage loss subtracts from the efficiency of the drive. It also results in additional heat generation which must be dissipated.

DC link reactors only reduce the ripple in the DC circuit of the drive and do not reduce the DC voltage level. They, therefore, do not reduce the AC output voltage. DC reactors generate additional heat in the drive, but because they are not an add-on, the VLT HVAC Drive is designed to accommodate this heat. The comparison between the AC and DC reactor's impact on the DC voltage is shown in figure 15.

AC line reactors act as a buffer between power line disturbances and the drive's input rectifier section. The VLT HVAC Drive, designed with metal oxide varistors (MOVs) and a resistor/capacitor (R/C) snubber circuit, protects the drive's input from noise on the AC power line and needs no additional buffering.

Conclusion

Distortion of the AC power line by adjustable frequency drives is a real concern in HVAC applications. It is important that drives provide filtering to reduce the impact that the drive may have on the rest of the building’s electrical system. The VLT HVAC Drive, designed for the requirements of HVAC applications, includes built-in DC link reactors as standard.

Test system data

Test data is based on the following system specifications.

Transformer Apparent Power	1.5 MVA
Primary voltage	11 kV
Secondary voltage	400 V
Impedance	6.1%
Short circuit power, secondary	25 MVA
Short circuit power, primary	350 MVA
Short circuit ratio	250
Drive input power	100 kW
H_c of drive without filter	745%
H_c of drive with filter	319%

The voltage is assumed to be 100% balanced. It is also assumed, for comparison purposes, that before adding drives to the system, no harmonic distortion was present.

Figure 15: On the left, the top curve demonstrates a 1% AC line reactor and the bottom curve is a 10% AC line reactor. The curves on the right show the impact of the equivalent DC link reactors

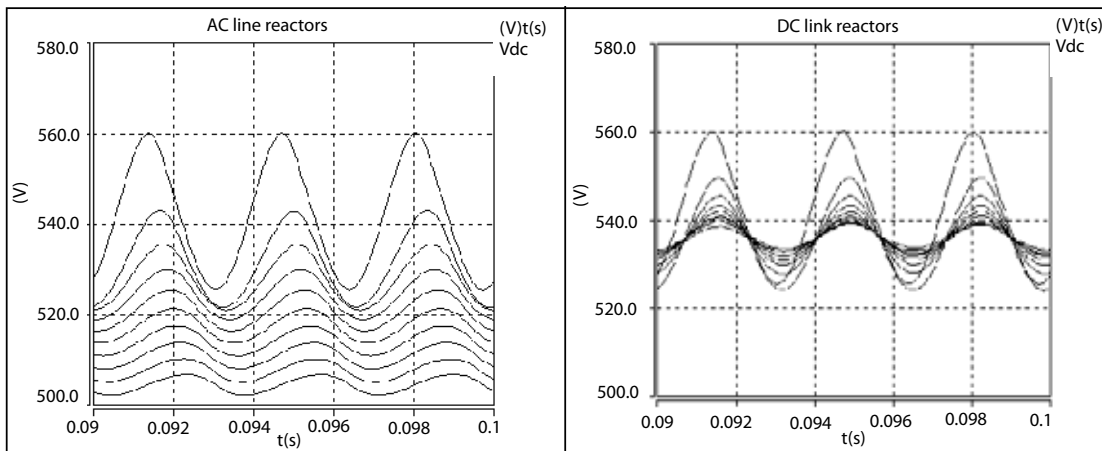

Figure 15. Impact of AC and DC reactors on DC voltage level.